

ABT-HC-CS-72

Product Description

The Standard Series Chromatography Refrigerators feature a microprocessor temperature controller and display, allowing for precise temperature control, verification, and recovery versus mechanical style thermostats. One interior duplex electrical outlet and one side all port hole is provided to simplify the setup and operation of laboratory procedures.

An interior fan driven, forced-draft air circulation system provides excellent temperature uniformity and recovery after door openings.

All Chromatography units require two electrical outlets.

Images



Certifications



General Description and Application

Storage capacity (cu. ft)	72 Cu. Ft.
Door	Three swing glass doors, self-closing, right and left hinged
Shelves	Twelve adjustable shelves (adjustable in 1/4" increments)
Mounting and installation	Swivel Casters
Interior lighting	LED interior lights are safety shielded and switch controlled
Airflow Management	Forced draft air circulation
External probe access	Probe access port (3/4")
Insulation	Cabinet is foamed-in-place with EPA compliant high density urethane foam
Exterior materials	White powder-coated steel interior and exterior
Access control	Keyed door lock
General warranty	One (1) year parts and labor warranty
Compressor warranty	Five (5) years compressor warranty
Product Weight (lbs)	693
Shipping Weight (lbs)	743
Rated Amperage	7.5 Amps
Power Plug/Power Cord	NEMA 5-15 plug
Facility Electrical Requirement	115V, 60 Hz, 7.5 Amps, 1/2 HP
Agency Listing and Certification	ETL, C-ETL listed and certified to UL471 standard

Refrigeration System	
Compressor	Hermetic
Refrigerant	Hydrocarbon, natural refrigerant (R290)
Defrost	Cycle

Controller, Configuration, Alarms and Monitoring	
Controller technology	Microprocessor Temperature Controller
Display technology	Digital Temperature Display and Alarm Module
Data Transfer	Non-applicable
Chart Recorder	Non-applicable
Adjustable Temperature Range	1°C to 10°C
External alarm connection	Remote alarm contacts
Disclaimers:	Specifications are subject to change. Please note: This unit requires two (2) outlets
Sample simulated digital temperature display	.1° Resolution
Alarms:	<ul style="list-style-type: none"> Audible and visual high/low temperature alarms Sensor error alarm Power failure alarm Remote alarm contacts Alarm validation (audible, visual, and remote alarm) Alarm mute with ring back

Dimensions					
	Width (in.)	Depth (in.)	Height (in.)	Door Swing (in.)	Total open Depth (in.)
Exterior	85.75"	34"	81.75"	24"	58"
Interior	76"	24.75"	52.5"		

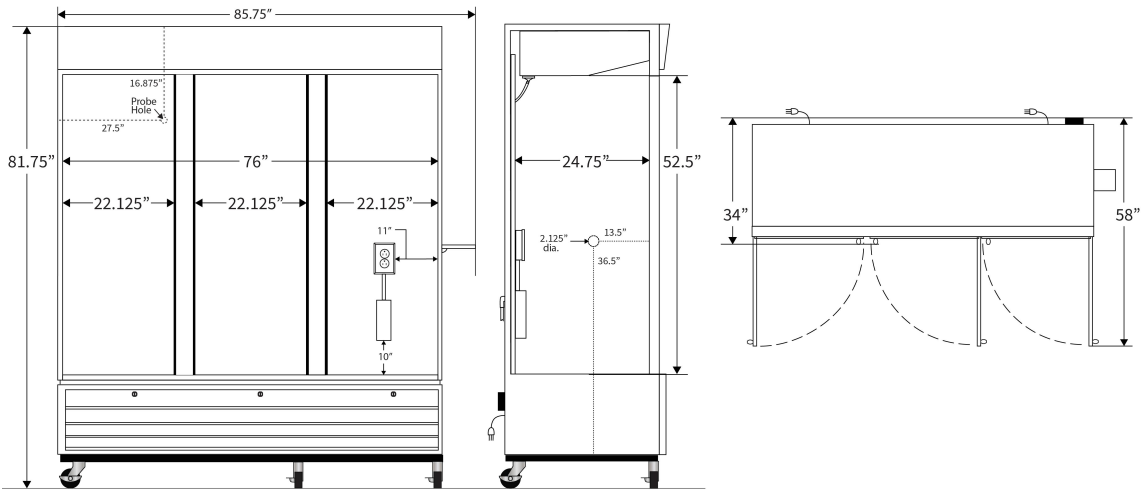

Contact		
Customer Service	800-648-4041 Option 3	customerservice@horizonscientific.com
Technical Service	800-648-4041 Option 5, Parts Option 4	technicalservice@horizonscientific.com