

ABT-HC-FRP-30-TS

Product Description

This 30 cu. ft. touchscreen flammable storage refrigerator offers a cutting-edge solution for storing volatile materials in laboratory and industrial settings. This refrigerator provides precise temperature control through microprocessor technology. Experience tight temperature uniformity with an operation range of 2°C to 10°C. This advanced unit features an intuitive touchscreen digital display that offers a user-friendly interface including digital 24-hour temperature charting with data logging capabilities. For enhanced safety, it includes a comprehensive array of customizable audible and visual alarms, such as high/low temperature, sensor error, power failure, door ajar, and low battery alerts—all alarms including a battery backup for continuous monitoring. Utilizing EPA SNAP compliant hydrocarbon refrigerants, this unit minimizes environmental impact while maximizing energy efficiency. It features a durable white powder-coated steel exterior, with a keyed door lock for added security. Adjustable interior shelving allows for versatile organization. With its integrated alarms and enhanced safety features, the ABT-HC-FRP-30-TS delivers advanced performance for the safe storage of flammable substances.

Images



Certifications



General Description and Application

Storage capacity (cu. ft)	30 Cu. Ft.
Door	One solid swing, right hinged; stainless steel door handle; magnetic door gasket
Shelves	Five adjustable
Drawers	Non-applicable
Mounting and Installation	Leveling Legs
Interior lighting	Non-applicable
Airflow Management	Forced draft circulation
External probe access	3/4" probe access port on rear wall
Insulation	EPA compliant high density urethane foam
Exterior materials	Powder coated steel
Access control	Keyed Door Lock
General warranty	Two (2) year parts and labor warranty
Compressor warranty	Five (5) year compressor parts warranty
Product Weight (lbs)	350
Shipping Weight (lbs)	380
Rated Amperage	3.1 Amps
Power Plug/Power Cord	NEMA 5-15P plug, 6 ft long cord
Facility Electrical Requirement	110 - 120V AC, 15A breaker, NEMA 5-15 receptacle
Agency Listing and Certification	UL listed per UL 60335-1 and UL 60335-2-89 standards; c UL listed per CSA C22.2 No. 120 standard, in compliance with the requirements for Flammable Materials Storage Refrigerators as defined by NFPA 99 and 45

Performance

Uniformity (Cabinet air)	+/- 1.6°C
Stability (Cabinet air)	+/- 1.0°C
Maximum temperature variation (Cabinet air)	3.6 °C Total
Energy Consumption (KWh/day)	< 1.7 KWh/day
Average Heat Rejection (BTU/hr)	520 BTU/hr
Pull down time to nominal operating temp	<35 min (empty)

Performance data based on an empty chamber at steady state using buffered temperature probes per Energy Star test method for Laboratory Grade Refrigerators and Freezers. Product loading, door openings, and ambient conditions will affect performance.

Refrigeration System	
Compressor	Hermetic, variable speed
Refrigerant	EPA SNAP compliant R600a Isobutane
Condenser	Static - exterior walls of cabinet
Evaporator	Fin and tube design, high efficiency fan, hazardous location rated
Defrost	Off-cycle defrost, no heat added

Controller, Configuration, Alarms and Monitoring	
Controller technology	Microprocessor temperature controller with variable frequency compressor control
Battery Backup	Temperature display and alarm only (no active cooling)
Display technology	Touch screen digital temperature display with user friendly interface, real-time operational display clock, active temperature scale bar display, resettable 1-point min/max history, digital 24- hour temperature chart, and temperature data logging
Temperature Setpoint Range Notes	Minimum temperature limited to avoid freezing
Adjustable Temperature Range	2°C to 10°C
External alarm connection	Remote alarm contacts
Alarms	Adjustable alarm volume, Audible and visual high and low temperature alarms, sensor error alarm, power failure alarm, door ajar alarm, low battery alarm, alarm validation (audible, visual, and remote alarm), alarm mute with ring back, and customizable alarm time delay settings
Display Probe	Product simulator bottle with glass bead media
Disclaimers	Refrigerator requires a minimum 4" of clearance around back and sides of the unit for proper ventilation (more if next to heat rejecting equipment) - improper installation will void the warranty and will lead to temperature maintenance issues, overheating and possible failure

Dimensions					
	Width (in.)	Depth (in.)	Height (in.)	Door Swing (in.)	Total open Depth (in.)
Exterior	35.75"	35.5"	72.5"	30.5"	66"
Interior	32"	22.5"	65"		

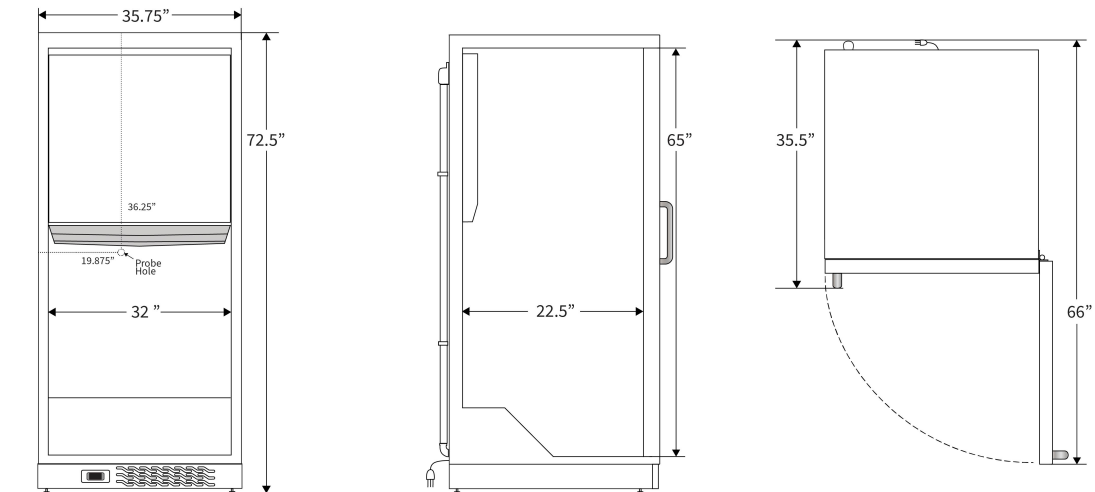

Contact		
Customer Service	800-648-4041 Option 3	customerservice@horizonscientific.com
Technical Service	800-648-4041 Option 5, Parts Option 4	technicalservice@horizonscientific.com

Rev_07232025