

Laboratory Fume Hoods & Enclosures



Fume hood experts.

As one of the first fume hood manufacturers, Labconco has extensive ventilation knowledge. Safe performance, durable construction and thoughtful design are hallmarks of our expertise.

We have the broadest line of fume hoods and ventilated enclosures in the industry. Instructional. Light duty. Ductless. For every application, there is a perfectly tailored Labconco solution.

Not sure what you need? Our ventilation specialists will analyze your application and recommend the right hood for your laboratory.

We've been taking care of customers since 1925. Let us put our experience to work for you.

Table of Contents

Protector® ClassMate® Laboratory Hoods

Features & Benefits	3
Vertical-Rising Sash Model Specifications	4
Combination Sash Model Specifications	5
Dimensional Data & Ordering Information	6
Airflow Data & Ordering Information	8
SpillStopper™ Work Surfaces	9
Accessories	10

Basic™ Laboratory Hoods

Features & Benefits	11
Specifications	12
Ordering Information & Dimensional Data	13
Accessories	15

Fiberglass 30 Laboratory Hoods

Specifications	16
Accessories & Dimensional Data	17

Protector® XVS™ Ventilation Stations

Features & Benefits	19
Specifications	20
Ordering Information & Dimensional Data	21

Protector® Demonstration Hoods

Specifications	22
Ordering Information & Dimensional Data	23

FilterMate™ Portable Exhausters

Specifications	24
Ordering Information & Dimensional Data	25
Carbon & HEPA Filters	26

Canopy Hoods

Flat Work Surfaces & Accessories	28
----------------------------------	----

Protector® XVS™ Ventilation Stations & Protector® Demonstration Hoods

Accessories	29
-------------	----

Protector® ClassMate® Laboratory Hoods

Features & Benefits

Protector ClassMate Laboratory Hoods were engineered and tested to achieve maximum containment at lowest face velocities. The result? The first classroom hood to achieve the SEFA 1 definition of a High Performance Fume Hood. These

patented* hoods have a clear back and sides and taller front viewing window for better visibility during instructor demonstrations. They may be installed away from walls, independently or back to back in an island configuration.

Durable

powder-coated steel frame.

⚡ **High performance** airflow design per SEFA 1 definition.

Performance tested to ASHRAE 110

Front panel may be easily removed for lamp replacement and access to electrical supply connections.

Tissue screen located directly below the exhaust outlet prevents debris from potentially damaging the remote blower.

Static viewing panel above the sash frame creates a 37.5" viewing height

Energy-efficient, LED vapor-proof lighting

is located behind a laminated safety glass shield and outside the hood interior for corrosion-resistance and easy replacement.

Ergonomic 5° angled sash and panel

allow closer, more comfortable viewing, without glare.

Clear, tempered safety glass sash, viewing panel, sides, back and baffle provide maximum visibility. All glass components except vertical-rising sashes are removable for cleaning.

Color-coded service fixtures for gas, cold water and other services have remote controls for use regardless of sash position. Each hood is factory prepared for up to eight remote controlled service fixtures.

⚡ **High performance baffle directs airflow to the rear of the interior** for efficient airflow.

Low profile trough below air foil contains spills. Trough is the same depth as the work surface (1.25") and requires no cabinet overhang. Air foil pivots up for cleaning.

⚡ **Ergonomic air foil** allows air to sweep the work surface maximizing containment. Clean-Sweep** openings pull inflow air from under the air foil forcing air into non-turbulent airstreams to create a protective barrier.

ETL-listed Hoods carry the ETL mark signifying that they conform to UL 61010-1 and 1805 and CAN/CSA C22.2 No. 61010-1.



Service access plates provide inside and front access to plumbing connections to simplify installation and service.

Anti-racking vertical-rising sash with chain drive for smooth operation. When raised, the sash does not extend above the fume hood. Contact Labconco for ordering information on auto-return sashes.

Combination horizontal-sliding/vertical-rising sashes are provided on some models. One integral sash stop prevents raising the vertical sash above the half-open (14") or 60% open (18") position unless manually defeated by the operator.



Pre-wired electrical components Lights, switches and electrical duplex receptacle (on applicable models) are factory-wired to the hood's junction box.

⚡ Labconco exclusive feature

*U.S. Design Patent No. 472,645

**U.S. Patent No. 6,461,233

Protector® ClassMate® Laboratory Hoods

with Vertical-Rising Sashes



All models feature:

- ❖ High performance hood per SEFA 1 definition
- ❖ Patented* design
 - By-pass airflow design
 - Glacier white powder-coated steel frame
- ❖ Ergonomic, low-profile air foil with aerodynamic Clean-Sweep** openings and spill trough
- Clear, 1/4" thick, tempered safety glass sides, back, baffle and viewing panel
- 5° angled stationary viewing panel and sash
- Chain-driven sash with anti-racking shaft and powder-coated steel frames
- Sash stop at 18" height from work surface (60% open). Can be field modified to 14" from work surface
- ❖ Powder-coated aluminum sash handle with aerodynamic Clean-Sweep** airflow openings
- ❖ 3-piece glass baffle pivots for cleaning
- ❖ Cord-Keeper™ slots on left and right side of air foil
- Pre-wired LED lighting, light switch and blower switch

❖ Labconco exclusive feature

- Powder-coated stainless steel tissue screen located below exhaust outlet
- Removable front panel, side panels and interior cover plates for access to plumbing and electrical wiring
- Powder-coated stainless steel 12.8" ID exhaust connection

Standards conformance & regulations:

- CFR 29, Part 1910
- SEFA 1
- NFPA 45
- ASHRAE 110
- ANSI Z9.5
- UL 61010-1
- CAN/CSA C22.2 No. 61010.1
- UL 1805
- SEFA 8

Fixture models may feature:

- Two pre-plumbed service fixtures with forged brass valves, lower right side with brass tubing for gas and lower left side with copper tubing for cold water. Components for converting either or both

fixtures to air and vacuum are provided.

Inlet tubing is not provided

- One pre-wired GFCI electrical duplex receptacle on lower right side

Required accessories (not included):

- Remote blower
- Ductwork
- Work surface. See page 9
- Base cabinet

Optional accessories for on-site installation include (see page 10):

- Distillation Grid Kits
- Guardian Airflow Monitors
- Upper Rear Finish Panel Kits
- Electrical Receptacle Kits
- Dual Exhaust Adapter
- Service Fixtures. See manual

*U.S. Design Patent No. 472,645

**U.S. Patent No. 6,461,233



 Heights of switches, electrical receptacles and service fixtures meet requirements of Americans with Disabilities Act (ADA).

Protector® ClassMate® Laboratory Hoods

with Combination Horizontal-Sliding/Vertical-Rising Sashes



All models feature:

- * High performance hood per SEFA 1 definition
- * Patented* design
 - By-pass airflow design
 - Glacier white powder-coated steel frame
- * Ergonomic, low-profile air foil with aerodynamic Clean-Sweep** openings and spill trough
- Clear, 1/4" thick, tempered safety glass sides, back, baffle and viewing panel
- Combination horizontal-sliding/vertical-rising sashes that allow the operator to use the hood with sashes half open either horizontally or vertically
- Sash stop at 14" height from work surface (50% vertical opening). Can be field modified to 18" from work surface
- 5° angled stationary viewing panel and sash
- Chain-driven sash with anti-racking shaft and powder-coated steel frames
- * 3-piece glass baffle pivots for cleaning
- * Powder-coated steel sash handle with aerodynamic Clean-Sweep** airflow openings

* Labconco exclusive feature

- * Cord-Keeper™ slots on left and right side of air foil
- Pre-wired LED lighting, light switch and blower switch
- Powder-coated stainless steel tissue screen located below exhaust outlet
- Removable front panel, side panels and interior cover plates for access to plumbing and electrical wiring
- Powder-coated stainless steel 12.8" ID exhaust connection

Standards conformance & regulations:

- CFR 29, Part 1910
- SEFA 1
- NFPA 45
- ASHRAE 110
- ANSI Z9.5
- UL 61010-1
- CAN/CSA C22.2 No. 61010.1
- UL 1805
- SEFA 8

Fixture models may feature:

- Two pre-plumbed service fixtures with forged brass valves, lower right side with

brass tubing for gas and lower left side with copper tubing for cold water. Components for converting either or both fixtures to air and vacuum are provided.

Inlet tubing is not provided

- One pre-wired GFCI electrical duplex receptacle on lower right side

Required accessories (not included):

- Remote blower
- Ductwork
- Work surface. See page 9
- Base cabinet

Optional accessories for on-site installation include (see page 10):

- Distillation Grid Kits
- Guardian Airflow Monitors
- Upper Rear Finish Panel Kits
- Electrical Receptacle Kits
- Dual Exhaust Adapter
- Service Fixtures. See manual

*U.S. Design Patent No. 472,645

**U.S. Patent No. 6,461,233

 Heights of switches, electrical receptacles and service fixtures meet requirements of ADA.



Protector® ClassMate® Laboratory Hoods

Dimensional Data

	A*	B*	C*	D*
4' Hood	48.0" (121.9 cm)	43.5" (110.5 cm)	20.5" (52.2 cm)	24.0" (61.0 cm)
5' Hood	60.0" (152.4 cm)	55.5" (141.0 cm)	26.5" (67.3 cm)	30.0" (76.2 cm)
6' Hood	72.0" (182.9 cm)	67.5" (171.5 cm)	32.5" (82.6 cm)	36.0" (91.4 cm)

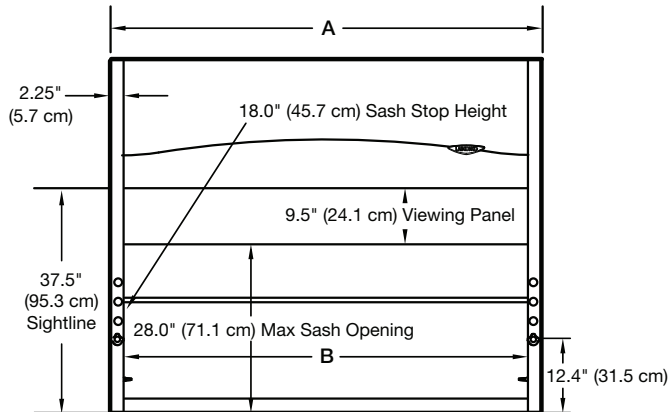

FRONT
(Vertical-Rising Sash Models)

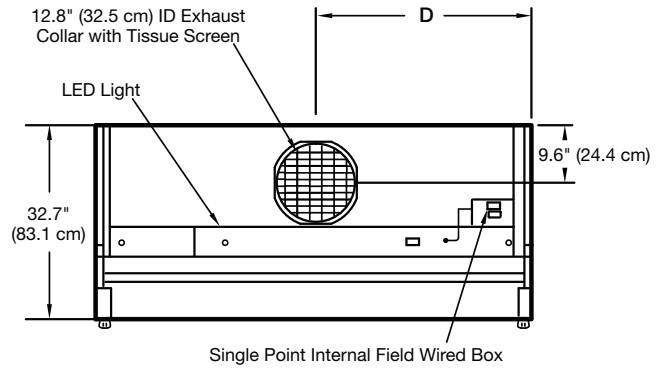

TOP
(All Models)

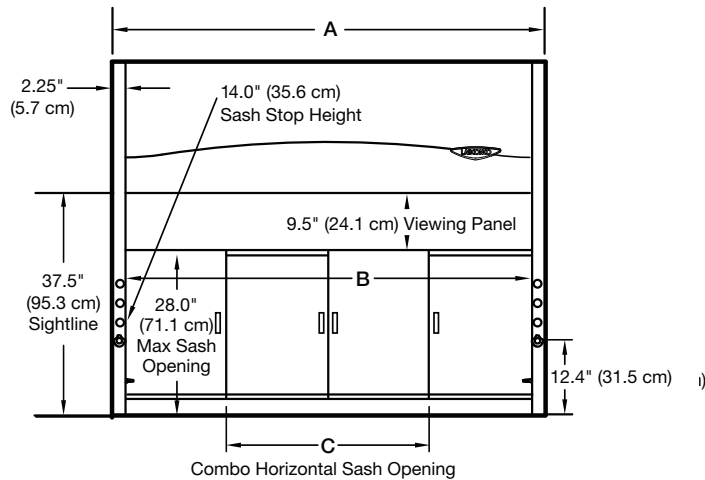

FRONT
(Combination Sash Models)

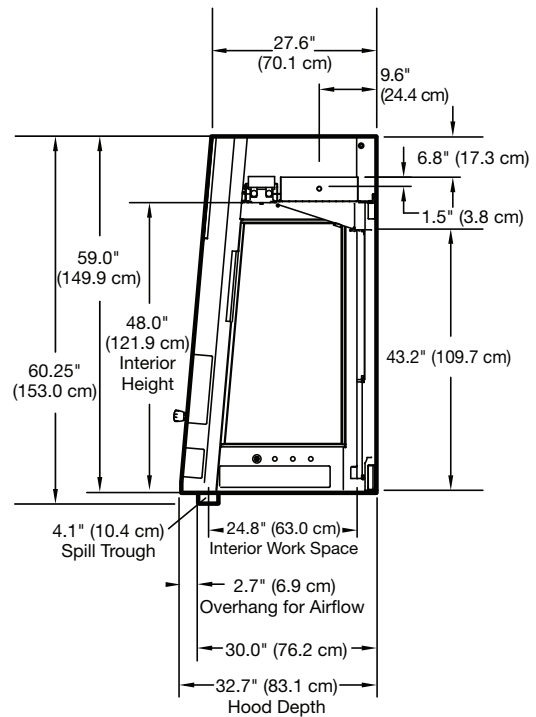

SIDE
(All Models)

*Inches (centimeters)
Contact Labconco at (800) 821-5525 or (816) 333-8811 for detailed AutoCAD drawings.

Protector® ClassMate® Laboratory Hoods

Dimensional Data

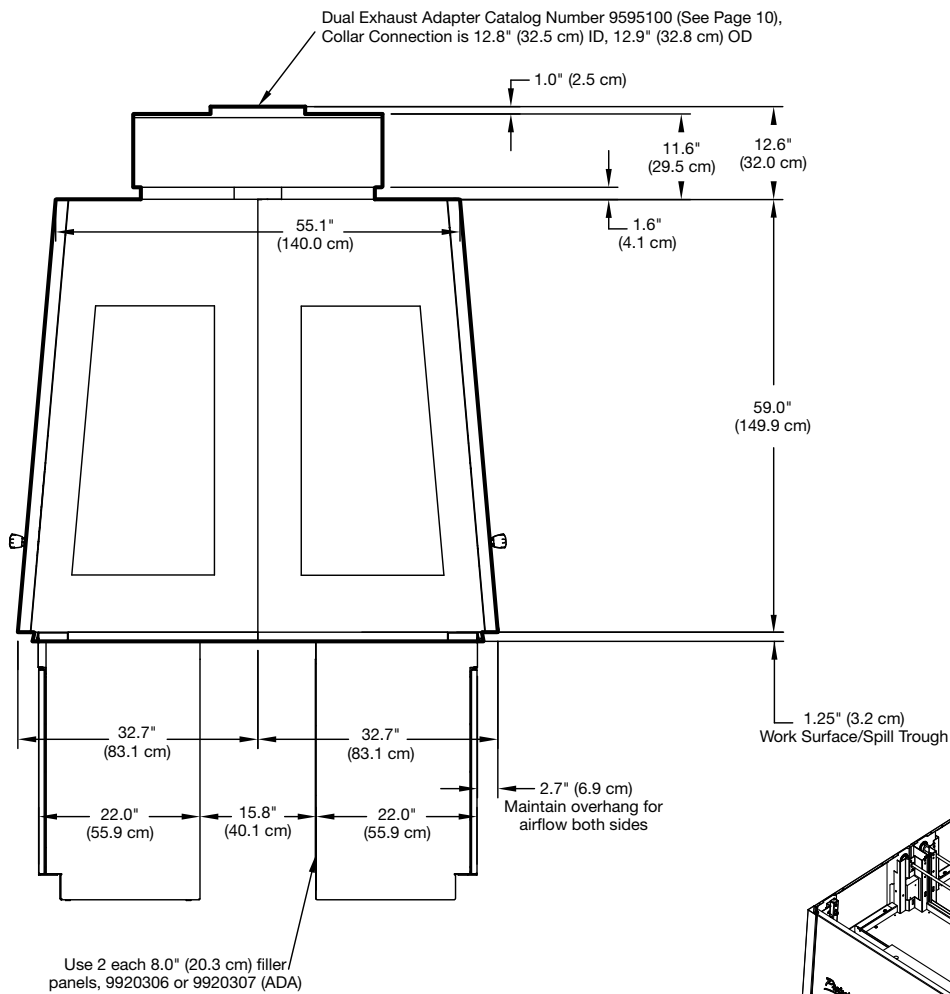

DUAL SIDE
(All Models)

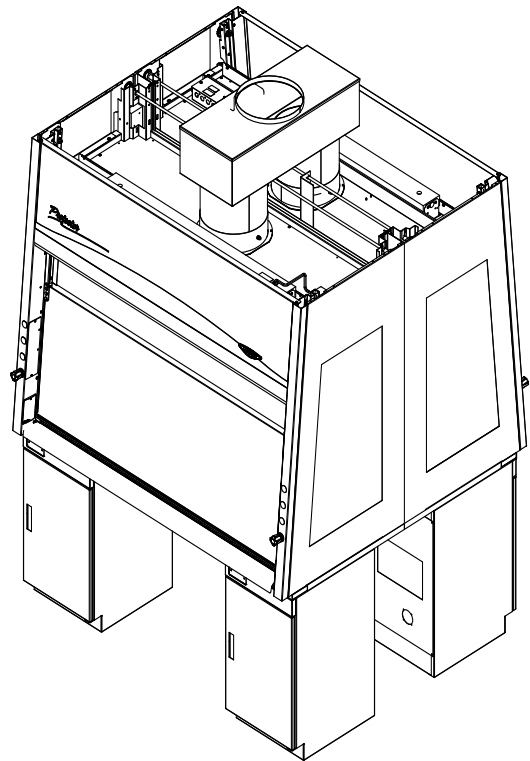

ISO
(All Models)

Protector® ClassMate® Laboratory Hoods

Ordering Information and Airflow Data

Catalog Number Configurator:

Use this key to configure the nine digit catalog number to order your Protector ClassMate Laboratory Hood.

1 6 0 0 1

Select the **WIDTH** of your fume hood. This is the fourth digit of your catalog number. Shipping weight is also noted. Add 10 lbs. (5 kg) for fixtured models.

- 4 = 4' (122 cm) 6 = 6' (183 cm)
 390 lbs. (177 kg) 550 lbs. (249 kg)
- 5 = 5' (152 cm)
 480 lbs. (218 kg)

Select the **SASH STYLE** available for your hood width. This is the sixth digit of your catalog number. For combination sash models add 35 lbs. (16 kg) for 4' models, 40 lbs. (18 kg) for 5' models and 50 lbs. (22 kg) for 6' models to the shipping weight noted above.

- 4 = Vertical-Rising Sash
 5 = Combination Sash

Select the **ELECTRICAL REQUIREMENTS, SERVICE FIXTURES** and **GFCI ELECTRICAL DUPLEX RECEPTACLE** combination you desire. These are the eighth and ninth digits of your catalog number.

Electrical Requirements	No Service Fixtures	Two Service Fixtures	Two Service Fixtures & GFCI Duplex**
100-115V, 50/60 Hz, 10A	00	—	02
208-230V, 50/60 Hz, 5A	20	21	—

Vertical-Rising Sash Models CFM and Static Pressure

Face Velocity (fpm)	Total Exhaust CFM and Static Pressure					
	4' Hood		5' Hood		6' Hood	
	CFM	s.p.	CFM	s.p.	CFM	s.p.
Sash @ Full Open (28")*						
100	785	0.44"	995	0.54"	1225	0.72"
80	625	0.28"	795	0.35"	980	0.46"
60	470	0.16"	595	0.19"	735	0.26"
Sash @ 62.5% Open (18")*						
100	495	0.18"	625	0.22"	775	0.29"
80	395	0.12"	495	0.14"	620	0.19"
60	295	0.07"	375	0.08"	465	0.10"

Combination Sash Models CFM and Static Pressure

Face Velocity (fpm)	Total Exhaust CFM and Static Pressure					
	4' Hood		5' Hood		6' Hood	
	CFM	s.p.	CFM	s.p.	CFM	s.p.
Sash @ 50% Open (horizontally with 2 sash panes open or vertically with 14" sash opening height)						
100	405	0.12"	520	0.15"	635	0.19"
80	325	0.08"	415	0.09"	510	0.12"
60	245	0.04"	315	0.05"	385	0.07"

*Contact Labconco for other sash opening height data.

**Hoods with GFCI electrical duplex are rated at 20 amps.

Protector® ClassMate® Laboratory Hoods

SpillStopper™ Work Surfaces



Molded from a special formulation of corrosion-resistant epoxy resins. Dished and contoured to conform to the interior liner of Protector ClassMate Laboratory Hoods. May be ordered with an oval cupsink cutout. **Cupsink is sold separately (see below).** See page 28 for deck-mounted accessories, which require custom cutouts.

Catalog Number Configurator:

Use this key to configure the seven digit catalog number to order your SpillStopper Dished Solid Epoxy Work Surface for use with Protector ClassMate Laboratory Hoods.

9 6 0 0

Select the **NOMINAL WIDTH** of your fume hood. This is the fifth digit of your catalog number. Shipping weight is also noted.

- 4** = 4' (122 cm)
110 lbs. (50 kg)
- 5** = 5' (152 cm)
150 lbs. (68 kg)
- 6** = 6' (183 cm)
205 lbs. (93 kg)

Select a **LEFT CUPSINK CUTOUT** option (cupsink is sold separately). This is the sixth digit of your catalog number.

- 0** = None
- 1** = Rear
- 2** = Side*

Select a **RIGHT CUPSINK CUTOUT** option (cupsink is sold separately). This is the seventh digit of your catalog number.

- 0** = None
- 1** = Rear
- 2** = Side*

Dimensional Data

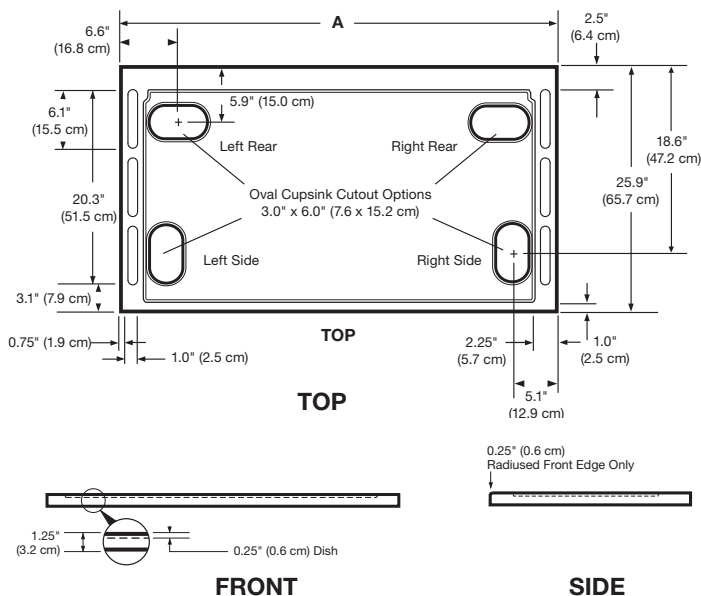

4005200—Oval Polypropylene Cupsink.

Mounts in work surface with cupsink cutout. 3.0" x 6.0". 1.5" National Pipe Straight Mechanical thread. Shipping weight 4.0 lbs. (1.8 kg)

*Not compatible with Protector Solvent Storage Cabinets.

Protector® ClassMate® Laboratory Hoods

Accessories

Upper Rear Finish Panel Kits. Hide the hood's upper components and provide finished appearance for the rear of the hood. Recommended when hood is mounted on a casework island (and exposed on the back). Glacier white powder-coated steel.

Catalog Number	Nominal Width	Dimensions (w x h)	Shipping Weight
9562700	4 Feet	38.0" x 9.5" (96.5 x 24.1 cm)	20 lbs. (9 kg)
9562701	5 Feet	50.0" x 9.5" (127.0 x 24.1 cm)	25 lbs. (12 kg)
9562702	6 Feet	62.0" x 9.5" (157.5 x 24.1 cm)	30 lbs. (14 kg)

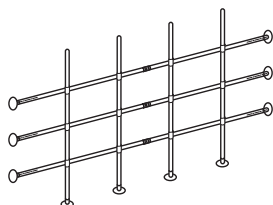

Distillation Grid Kits. Include stainless steel rods, connectors, instruction sheet and drill template.

Catalog Number	Nominal Width	Shipping Weight
6973300	4 Feet	15 lbs. (7 kg)
6973301	5 Feet	20 lbs. (9 kg)
6973302	6 Feet	25 lbs. (11 kg)



Duplex Electrical Receptacle Kit
9851413



British (UK)



Schuko



China



Australia



India-South Africa

Electrical Receptacle Kits. For mounting in left or right side of any 4', 5' or 6' Protector ClassMate Hood. Each kit includes an electrical receptacle, wiring and receptacle cover plate. The International GFCI Switch is mountable in one corner post location above or below any international single outlet but only allowed on custom corner posts. Contact Labconco for ordering information.

Catalog Number	Kits	Outlet Type	Shipping Weight
9851023	115V, 20A AC, 60 Hz	Duplex, U.S.	4.0 lbs. (1.8 kg)
9851423	115V, 20A AC, GFCI, 60 Hz	Duplex, U.S.	4.0 lbs. (1.8 kg)
9854123	230V, 20A AC, 60 Hz	Duplex, U.S.	4.0 lbs. (1.8 kg)
9412423	230V, 13A AC, 50 Hz	Single, British (UK)	4.0 lbs. (1.8 kg)
9412623	230V, 16A AC, 50 Hz	Single, Schuko	4.0 lbs. (1.8 kg)
9412823	230V, 10A AC, 50 Hz	Single, China	4.0 lbs. (1.8 kg)
9413023	230V, 10A AC, 50 Hz	Single, Australia	4.0 lbs. (1.8 kg)
9413823	230V, 6-16A AC, 50 Hz	Single, India-South Africa	4.0 lbs. (1.8 kg)
9414223	International GFCI Switch, 16A	Not Applicable	4.0 lbs. (1.8 kg)

Contact Labconco at (800) 821-5525 or (816) 333-8811 for ordering information on Service Fixture Kits.



Guardian™ Digital Airflow Monitors.

Sense and alert the operator to low airflow conditions. LCD displays actual airflow in fpm or m/sec. Audible/visual alarm alerts the user to sustained low velocity condition. Calibration instructions displayed on LCD. Each monitor includes a sensor, external alarm, night setback and alarm mute functions. Contact Labconco for optional temperature sensor and optional RS-485 port for Modbus** RTU communication. Digits may be disabled.

Catalog Number	Electrical Requirements	Shipping Weight
9413400	100-115V, 50/60 Hz	6.0 lbs. (2.7 kg)
9413401*	208-230V, 50/60 Hz	6.0 lbs. (2.7 kg)

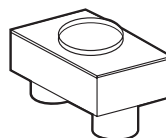

Dual Exhaust Adapter. Type 304 stainless steel common exhaust adapter allows two Protector ClassMate Hoods mounted back-to-back to be exhausted from a single 12" (12.75" OD pipe) nominal diameter duct. Extends above the hood by 12.6".

Catalog Number	Description	Dimensions (w x d x h)	Shipping Weight
9595100	12 x 12 x 12 Dual Exhaust Adapter	34.1" x 14.1" x 21.0" (86.6 x 35.8 x 53.3 cm)	20 lbs. (9 kg)

*International electrical configuration

**Modbus is a registered trademark of Schneider Automation

Basic™ Laboratory Hoods

Features & Benefits

Basic 47 and 70 Laboratory Hoods are designed for modular laboratories, classrooms and light duty applications where safe ventilation is required.

Constructed of powder-coated steel, Basic Hoods are economical and have a smaller overall height and depth than traditional hoods so they fit in areas with low ceilings or narrow aisles.

Front panel may be removed for access to blower and electrical connections.

❖ **Versatile blower** mounts on top of the hood liner or in a remote location. Hoods are also available without blower.

CE mark*
Contact Labconco for specific 230V, 50 Hz models that conform to CE (European Community) requirements for electrical safety and electromagnetic compatibility.

Two-piece baffle is adjustable.

Durable and attractive exterior is glacier white powder-coated steel.

The right side fixture panel is factory-prepared for up to three color-coded service fixtures, one duplex electrical receptacle and an airflow monitor.

Vapor-proof lighting illuminates the interior
Explosion-proof models include an explosion-proof light fixture (**bulb not included**).

Top of the hood liner factory-prepared to accommodate two customer-supplied apparatus rods

Vertical-rising tempered safety glass sash protects the operator while providing excellent visibility.

ETL-listed
Hoods carry the ETL mark signifying that they are certified to UL 61010-1 and CAN/CSA C22.2 No. 61010.1.

The curved air foil directs airflow into the hood to minimize turbulence and ensure fume containment. The foil lifts off for cleaning.

Unassembled models available
Components fit into a carton less than one half its assembled size. The compact container is more economical to ship and store than assembled hood cartons and transports readily to remote locations. Assembly is simple and fast. **Unassembled models are not pre-wired.**

Performance tested to ASHRAE 110

Right interior wall factory-prepared to accommodate an accessory cupsink and turret (sold separately)

Durable powder-coated 16 gauge steel liner resists chemical degradation.

Pre-wired electrical components
Incandescent lighting and switches are factory-wired to the hood's junction box. **Explosion-proof models are furnished without switches and wiring as these must conform to varying local codes.**

Compact dimensions accommodate tight installations



❖ Labconco exclusive feature

*Contact Labconco for specific models.

Basic™ Laboratory Hoods

Specifications



All models feature:

- By-pass airflow design
- Curved air foil that lifts off for cleaning
- Glacier white powder-coated, 16 gauge steel exterior and interior
- Two-piece adjustable baffle
- 3/16" thick tempered safety glass vertical-rising sash with powder-coated steel sash handle
- Removable front panel for access to electrical wiring
- Right side fixture panel factory-prepared for up to three service fixtures, one duplex electrical receptacle and one airflow monitor (**fixtures, receptacle and monitor not included**)
- Right interior wall factory-prepared for one cupsink and turret (**cupsink and turret not included**)

- Powder-coated steel 10.3" OD exhaust connection

Standards conformance & regulations:

- CFR 29, Part 1910
- SEFA 1
- NFPA 45
- ASHRAE 110
- ANSI Z9.5*
- UL 61010-1
- CAN/CSA C22.2 No. 61010.1
- UL 1805
- SEFA 8
- CE Conformity Marking (220V models)**

Vapor-proof models feature:

- Pre-wired 100-watt vapor-proof LED light, light and blower switches

Explosion-proof models feature:

- Explosion-proof 100-watt light fixture (**Requires installation. Bulb not included.**)
- **Furnished without switches and wiring as these must conform to varying local codes**

Models with blower module feature:

- Belt-driven blower with adjustable sheave
- Powder-coated steel base and housing
- Corrosion-resistant coated steel impeller

Unassembled models feature:

- Basic 47 Hood carton dimensions: 51.0" w x 39.0" d x 14.5" h
- Basic 70 Hood carton dimensions: 74.0" w x 39.0" d x 14.5" h
- Blower carton dimensions (if applicable): 20.0" w x 28.0" d x 16.0" h

Required accessories (not included):

- Blower†
- Ductwork
- Work surface. See page 28
- Base cabinet or stand

Optional accessories for on-site installation include (see page 15):

- Service Fixture Kits
- Electrical Duplex Kits
- Guardian Airflow Monitor Kits
- Cupsink and Turret Kit
- Sash Stop Kit
- Right Side Finish Panel Kit

*Does not apply to models with blower module.

**Contact Labconco for specific models.



†Many models include a blower module.

♿ Heights of switches, electrical receptacles and service fixtures meet requirements of ADA.

Basic™ 47 Laboratory Hoods

Ordering Information & Dimensional Data

Basic 47 Hoods with Blower Module

Capable of overcoming a maximum external static pressure of .25" H₂O at 720 CFM (100 fpm).

Overall dimensions: 47.0" wide x 25.0" deep x 53.0" high (with blower module mounted on top of hood).

Catalog Number	Nominal Width	Electrical Requirements	Light Type	Blower Motor	Equivalent Resistance*		Assembly Configuration	Shipping Weight
					10" dia.	12" dia.		
2247300	4 Feet	115V, 60 Hz	Vapor-Proof	1/3 HP	100'	250'	Fully Assembled	370 lbs. (168 kg)
2247301**	4 Feet	220V, 50 Hz	Vapor-Proof	1/2 HP	100'	250'	Fully Assembled	370 lbs. (168 kg)
2247500	4 Feet	115/230V, 60 Hz	EP†	1/3 HP, EP	100'	250'	Fully Assembled	375 lbs. (170 kg)
2247501**	4 Feet	220V, 50 Hz	EP†	1/3 HP, EP	100'	250'	Fully Assembled	375 lbs. (170 kg)
2246603	4 Feet	115V, 60 Hz	Vapor-Proof	1/3 HP	100'	250'	Unassembled	272 lbs. (123 kg) 29 lbs. (13 kg)††
2246604**	4 Feet	220V, 50 Hz	Vapor-Proof	1/2 HP	100'	250'	Unassembled	272 lbs. (123 kg) 29 lbs. (13 kg)††
2246605	4 Feet	115/230V, 60 Hz	EP†	1/3 HP, EP	100'	250'	Unassembled	272 lbs. (123 kg) 41 lbs. (19 kg)††
2246606**	4 Feet	220V, 50 Hz	EP†	1/3 HP, EP	100'	250'	Unassembled	272 lbs. (123 kg) 41 lbs. (19 kg)††

Basic 47 Hoods for use with remote blower

Static pressure loss does not exceed .35" H₂O at 100 fpm (720 CFM). Overall dimensions: 47.0" wide x 25.0" deep x 48.0" high.

Catalog Number	Nominal Width	Electrical Requirements	Light Type	Assembly Configuration	Shipping Weight
2247400	4 Feet	100-115V, 50/60 Hz	Vapor-Proof	Fully Assembled	275 lbs. (125 kg)
2247401**	4 Feet	208-230V, 50/60 Hz	Vapor-Proof	Fully Assembled	275 lbs. (125 kg)
2246600	4 Feet	100-115V, 50/60 Hz	Vapor-Proof	Unassembled	272 lbs. (123 kg)
2246601**	4 Feet	208-230V, 50/60 Hz	Vapor-Proof	Unassembled	272 lbs. (123 kg)
2246602	4 Feet	115/230V, 50/60 Hz	EP†	Unassembled	272 lbs. (123 kg)

EP = explosion-proof

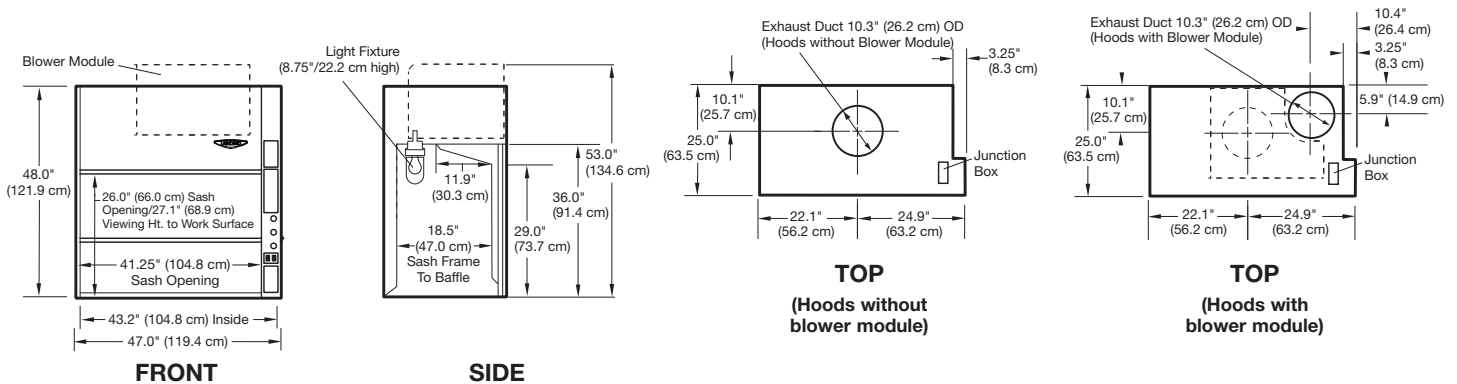

See page 15 for blower module detail.

*Maximum length of straight duct to achieve 100 fpm face velocity.
 **International electrical configuration
 †Bulb not included
 ††Shipping weight of separate blower carton

Basic™ Laboratory Hoods

Accessories



Guardian™ 500 Airflow Monitor Kits. Audible/visual alarm alerts user to low face velocity. For installation in a factory-prepared cutout on upper portion of right side fixture panel. Shipping weight 6.0 lbs. (2.7 kg)

Catalog Number	Description
9743208	For 115V, 60 Hz operation
9743210**	For 230V, 50 Hz operation



Guardian™ 1000 Digital Airflow Monitor Kits. LCD displays average face velocity. Audible/visual alarm alerts user to low or high face velocity. For installation in a factory-prepared cutout on upper portion of right side fixture panel. Shipping weight 6.0 lbs. (2.7 kg)

Catalog Number	Description
9743207	For 115V, 60 Hz operation
9743209**	For 230V, 50 Hz operation

Duplex Electrical Receptacle Kits. Include duplex electrical receptacle, junction box and receptacle cover plate. For mounting on the lower right side fixture panel. **Electrical wiring is not included.** Shipping weight 4.0 lbs. (1.8 kg)

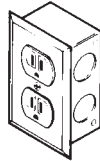

Catalog Number	Description
4844400	115V, 20A AC
4844401	115V, 20A AC, GFCI

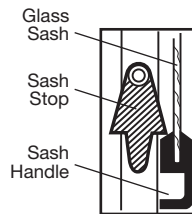

4965901—Sash Stop Kit. Restricts how far the sash may be opened. This small plastic device may be easily installed on the left side of Basic Hoods. Shipping weight 0.5 lb. (0.2 kg)



4852500—Cupsink and Turret Kit. Polypropylene cupsink, 3.0" x 6.0", and chrome turret mount on right side wall. **Plumbing pipe is not included.** Shipping weight 0.5 lb. (0.2 kg)

4878600—Right Side Finish Panel Kit. Recommended. Includes a glacier white powder-coated steel panel to provide a finished appearance to the right side of the hood. Panel hides the exposed plumbing when service fixtures are installed. Not for use with 4852500 Cupsink and Turret. Shipping weight 20 lbs. (9 kg)

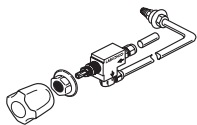

Standard Service Fixture Kits. Include one remotely-controlled service fixture with 0.25" diameter valve and tubing, color-coded fixture knob and color-coded hose connector. For mounting on the right side fixture panel. Shipping weight 4.0 lbs. (1.8 kg)

Catalog Number	Kit	Tubing	Valve	Knob/Connector Color	Max. Flow Rate	Max. Working Pressure*
2832600	Cold Water (CW)	Copper	Brass	Green	3.5 GPM (13.2 LPM)	40 psi
2832601	Hot Water (HW)	Copper	Brass	Red	3.5 GPM (13.2 LPM)	40 psi
2832602	Deionized/Distilled Water (DW)	Stainless Steel	Nickel-Plated & Stainless Steel	White	3.5 GPM (13.2 LPM)	40 psi
2832603	Vacuum (VAC)	Copper	Brass	Yellow	8.6 CFM	14.7 psi
2832604	Air (AIR)	Copper	Brass	Orange	23.7 CFM	40 psi
2832605	Gas (GAS)	Brass	Brass	Blue	29.0 CFM (441 BTU/sec)	40 psi
2832606	Nitrogen (NIT)	Copper	Brass	Brown	24.1 CFM	40 psi
2832607	Argon (ARG)	Copper	Brass	Gray	20.2 CFM	40 psi
2832608	Steam (STM)	Copper	Brass	Black	0.5 LBM/min	40 psi

GPM = gallons per minute LPM = liters per minute CFM = cubic feet per minute BTU/sec = British thermal unit per second
LBM/min = pounds mass per minute

Blower Module Detail

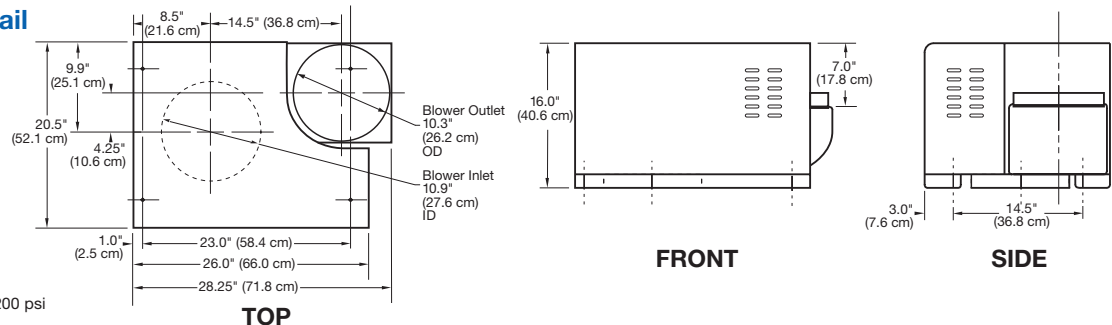

*Maximum allowable pressure is 200 psi with a working pressure of 40 psi.
 **International electrical configuration

Fiberglass 30 Laboratory Hoods

Specifications & Ordering Information



Compact Fiberglass 30 Laboratory Hoods are designed for research, educational and clinical applications requiring small working space and efficient fume removal. These hoods feature a corrosion-resistant, one-piece molded fiberglass liner.

All models feature:

- By-pass airflow design
- Durable glacier white powder-coated steel exterior
- One-piece molded fiberglass interior and pre-set baffle with flame spread index less than 25 per ASTM E84
- 3/16" thick tempered safety glass vertical-rising sash with powder-coated aluminum handle

- Pivoting air foil
- Right side fixture panel factory-prepared for up to three service fixtures, one electrical duplex and one airflow monitor (kits are sold separately)
- 6.7" ID fiberglass exhaust connection

Standards conformance & regulations:

- CFR 29, Part 1910
- SEFA 1
- NFPA 45
- ASHRAE 110
- ANSI Z9.5*
- UL 61010-1
- CAN/CSA C22.2 No. 61010.1
- UL 1805
- SEFA 8
- CE Conformity Marking (230V models)**

⚠ **WARNING:** Cancer - P65Warnings.ca.gov (California only)

Models 3030000 and 3030001 feature:

- Built-in corrosion-resistant, direct drive exhaust blower capable of overcoming a maximum external static pressure of 0.12" H₂O at 310 CFM (100 fpm)
- Pre-wired 100 watt, vapor-proof LED lighting, light and blower switches

Models 3030002 and 3030003:

- Designed for use with remote blower (not included)
- Static pressure loss does not exceed 0.14" H₂O at 100 fpm (310 CFM)
- Pre-wired 100 watt, vapor-proof LED lighting, light and blower switches

Models 3030004 and 3030005 feature:

- Built-in corrosion-resistant, explosion-proof, direct drive exhaust blower capable of overcoming a maximum external static pressure of 0.12" H₂O at 310 CFM (100 fpm)
- **Furnished without light, switches or wiring. Wiring must conform to local codes** (Explosion-proof Light Fixture Kit is available. See page 17.)

Required accessories (not included):

- Ductwork
- Work surface. See page 28
- Base cabinet or stand

Optional accessories for on-site installation include (see page 17):

- Service Fixture Kits
- Electrical Duplex Kits
- Guardian Airflow Monitor Kits
- Explosion-Proof Light Fixture Kit



Catalog Number	Built-in Blower	Equivalent Resistance ^{††}		Electrical Requirements	Vapor-Proof Lamp	Dimensions (w x d x h)	Shipping Weight
		6" dia.	8" dia.				
3030000	1/10 HP, Std.	20'	80'	115V, 60 Hz	100 watt	30.0" x 30.2" x 48.0" (76.2 x 76.7 x 121.9 cm)	230 lbs. (104 kg)
3030001 [†]	1/3 HP, Std.	20'	80'	230V, 50 Hz	100 watt	30.0" x 30.2" x 52.0" (76.2 x 76.7 x 132.1 cm)	230 lbs. (104 kg)
3030002	None	—	—	115V, 60 Hz	100 watt	30.0" x 30.2" x 48.0" (76.2 x 76.7 x 121.9 cm)	210 lbs. (95 kg)
3030003 [†]	None	—	—	230V, 50 Hz	100 watt	30.0" x 30.2" x 48.0" (76.2 x 76.7 x 121.9 cm)	210 lbs. (95 kg)
3030004	1/4 HP, EP	20'	80'	115V, 60 Hz	None	30.0" x 30.2" x 54.0" (76.2 x 76.7 x 137.2 cm)	240 lbs. (109 kg)
3030005 [†]	1/3 HP, EP	20'	80'	230V, 50 Hz	None	30.0" x 30.2" x 54.0" (76.2 x 76.7 x 137.2 cm)	240 lbs. (109 kg)

EP = Explosion-proof

*Does not apply to models with built-in blowers.
**Contact Labconco for specific models.

[†]International electrical configuration
^{††}Maximum length of straight duct to achieve 100 fpm face velocity

Fiberglass 30 Laboratory Hoods

Accessories

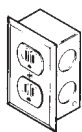

Duplex Electrical Receptacle Kits. Include duplex electrical receptacle, wiring, junction box and receptacle cover plate. For mounting on the lower right side fixture panel.

Catalog Number	Description	Shipping Weight
2834800	115V, 20A AC	4.0 lbs. (1.8 kg)
2834801	115V, 20A AC, GFCI	4.0 lbs. (1.8 kg)

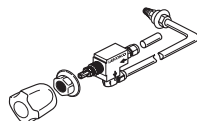

Standard Service Fixture Kits. Include one remotely-controlled service fixture with 0.25" diameter valve and tubing, color-coded fixture knob and color-coded hose connector. For mounting on the right side fixture panel. Shipping weight 4.0 lbs. (1.8 kg)

Catalog Number	Kit	Tubing	Valve	Knob/Connector Color	Max. Flow Rate	Max. Working Pressure*
2832600	Cold Water (CW)	Copper	Brass	Green	3.5 GPM (13.2 LPM)	40 psi
2832601	Hot Water (HW)	Copper	Brass	Red	3.5 GPM (13.2 LPM)	40 psi
2832602	Deionized/Distilled Water (DW)	Stainless Steel	Nickel-Plated & Stainless Steel	White	3.5 GPM (13.2 LPM)	40 psi
2832603	Vacuum (VAC)	Copper	Brass	Yellow	8.6 CFM	14.7 psi
2832604	Air (AIR)	Copper	Brass	Orange	23.7 CFM	40 psi
2832605	Gas (GAS)	Brass	Brass	Blue	29.0 CFM (441 BTU/sec)	40 psi
2832606	Nitrogen (NIT)	Copper	Brass	Brown	24.1 CFM	40 psi
2832607	Argon (ARG)	Copper	Brass	Gray	20.2 CFM	40 psi
2832608	Steam (STM)	Copper	Brass	Black	0.5 LBM/min	40 psi

GPM = gallons per minute LPM = liters per minute CFM = cubic feet per minute BTU/sec = British thermal unit per second
LBM/min = pounds mass per minute



Guardian™ 1000 Digital Airflow Monitor Kits. LCD displays average face velocity. Audible/visual alarm alerts user to low or high face velocity. For installation in a factory-prepared cutout on upper portion of right side fixture panel. Shipping weight 6.0 lbs. (2.7 kg)

Catalog Number	Description
9743201	For 115V, 60 Hz operation
9743205*	For 230V, 50 Hz operation



Guardian™ 500 Airflow Monitor Field Installation Kits. Audible/visual alarm alerts user to low face velocity. For installation in a factory-prepared cutout on upper portion of right side fixture panel. Shipping weight 6.0 lbs. (2.7 kg)

Catalog Number	Description
9743213	For 115V, 60 Hz operation
9743214*	For 230V, 50 Hz operation

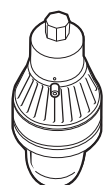

4892900—Explosion-Proof Light Fixture Kit. For mounting on Fiberglass 30 Hood 3030004 or 3030005. Includes explosion-proof incandescent/LED light fixture, mounting hardware and instructions. 13.0" h x 7.0" diameter (33.0 x 17.8 cm). 150 Watt maximum. Suitable for Class I, Group C & D and Class II, Group E & G room classifications per National Fire Protection Association (NFPA) 70. **Bulb and electrical wiring are not included.** Shipping weight 11 lbs. (5 kg)

*Maximum allowable pressure is 200 psi with a working pressure of 40 psi.

**International electrical configuration

Fiberglass 30 Laboratory Hoods

Dimensional Data

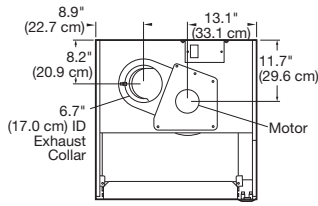

3030000
(with Built-in Blower)

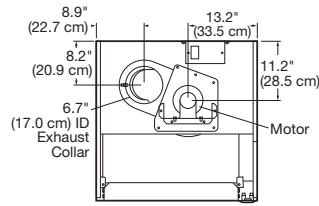

3030001
(with Built-in Blower)

TOP

TOP

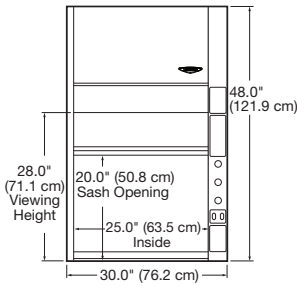

FRONT

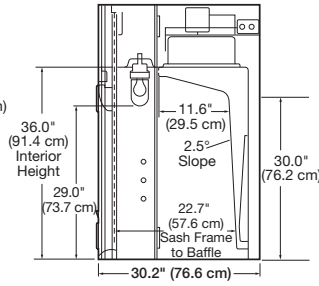

SIDE

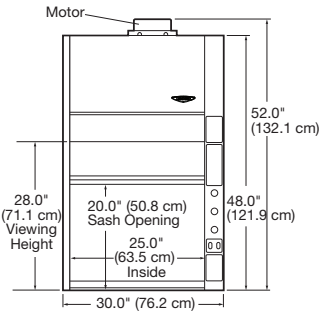

FRONT

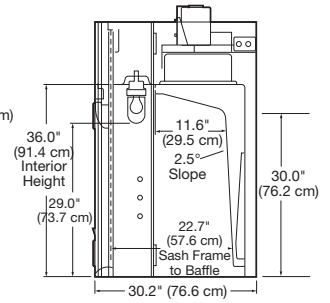

SIDE

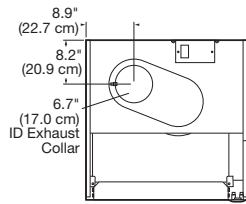

3030002 and 3030003
(for use with Remote Blower)

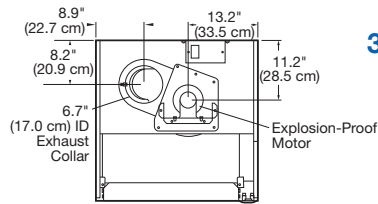

3030004 and 3030005
(with Built-in Explosion-Proof Blower)

TOP

TOP

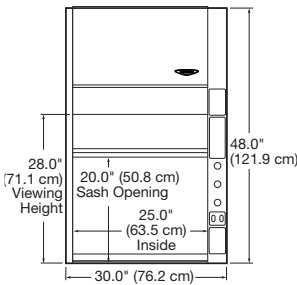

FRONT

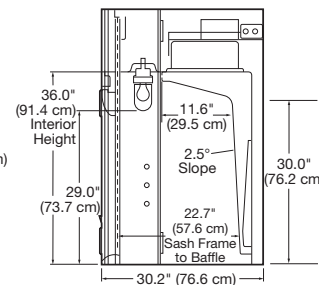

SIDE

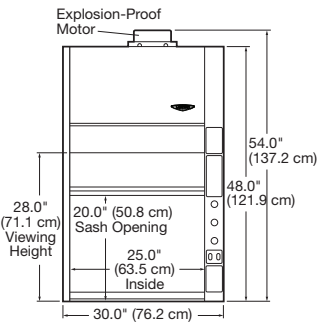

FRONT

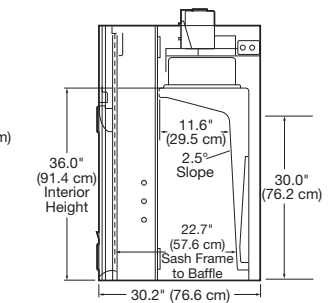

SIDE

Protector® XVS™ Ventilation Stations

Features & Benefits

Protector XVS Ventilation Stations provide an economical alternative to traditional fume hoods. With their low profile and clear sides, top and sash, these enclosures are well suited for classroom and educational laboratory environments. They may also be used as weighing stations, light duty fume hoods, solvent cleaning work bays, and veterinary pathology and cytology enclosures. XVS Stations exhaust less tempered room air, therefore

conserving more energy than traditional hoods. They have no switches, wiring or service fixtures.

Protector XVS Stations may be connected to a remote blower and exhausted to the outside. Or, they may be connected to the FilterMate Portable Exhauster(s), to remove fumes and vapors and/or hazardous particulates from the exhaust air without ducting.

❖ **Tempered safety glass front sash, sides and top** offer excellent visibility, ambient light and protection. Glass provides better fire, scratch and chemical resistance than acrylic and dissipates static charge.

❖ **Sturdy glacier white and gray powder-coated aluminum frame and steel rear plenum and baffle** dissipate static charge and provide durability and better chemical resistance compared to acrylic models. No plastic-to-plastic bonding is used.

❖ **Upper dilution air supply** introduces room air at the top of the sash to dilute contaminants in the upper chamber and bathes the back of the sash with clean air.

❖ **Patented* rear baffle with zones of perforations** promotes horizontal airflow to maximize containment. Baffle pivots down and is easily removable for cleaning.

Ergonomic angled sash allows a closer view, reduces glare and provides a more comfortable operating position than vertical sashes.

❖ **Patented* upper containment sash foil** bleeds air into the enclosure to direct concentrations of contaminants away from the operator's breathing zone.

❖ **Deep interior** easily accommodates a variety of apparatus including large balances. Models are available with a 23.4" interior depth. Some 5', 6' and 8' models have 30.0" interior depths.

Stationary sash opening limits exhaust demand, conserves costly tempered room air and requires a smaller remote blower than most fume hoods.

❖ **Side-entry air foils** allow air to sweep across the interior glass surfaces to enhance containment.

❖ **Patented* Clean-Sweep™ air foil** allows air to sweep the work surface for maximum containment. Airflow openings pull inflow air from under the air foil so that clean air continually flows through the air foil creating a constant barrier of protection from contaminants.

Two rear utility ports allow passage of tubing, electrical cords and interface cables from inside to back exterior for connection to services.

Particulate containment independently verified by SafeBridge Consultants, Inc.**

Flexible exhaust options. Rectangular exhaust openings on the top and bottom allow the Protector XVS Ventilation Station to be connected to ductwork for exhausting to the outside or to FilterMate™ Portable Exhauster(s) for filtered removal of fumes, particulates or powders. Using the bottom exhaust opening keeps ductwork hidden, maximizing room visibility.



❖ **Left-side mounted waste chute**, standard on some 5', 6' and 8' models, isolates contaminated waste in a sealable bag.

❖ Labconco exclusive feature

*U.S. Patent No. 6,461,233

**Contact Labconco for more information.

Protector® XVS™ Ventilation Stations

Specifications



8' Protector XVS Ventilation Station with Waste Chute 4868060



2' Protector XVS Ventilation Station 4862030

All models feature:

- By-pass airflow design
- * Clean-Sweep* air foil
- * Upper dilution air supply
- * Upper containment sash foil*
- * Zone-perforated, pivoting rear baffle*
- * Side-entry air foils
- Glacier white and gray powder-coated aluminum frame and steel rear plenum and baffle. No plastic-to-plastic bonding is used
- Clear 3/16" thick tempered safety glass top and sides and 1/4" thick sash
- * Ergonomic 20° angled and hinged, pivoting sash with wiping seal. Sashes on 5', 6' and 8' models incorporate an external gas-assist lift
- Models with 8.0" sash opening height have 16.5" locking height and 19.0" maximum loading height. Models with 10.0" or 12.0" sash opening height have 25.75" locking height and 28.25" maximum loading height
- Two utility ports with iris openings and plastic plugs
- 2.0" x 10.0" rectangular exhaust openings at the top and bottom. 5', 6' and 8' models include three openings on the top and bottom. Cover(s) provided for unused openings
- * Particulate containment independently verified by SafeBridge Consultants, Inc††
- Modified ASHRAE 110 conformity independently verified by ECT, Inc††

Standards conformance & regulations:

- SEFA 1
- Modified ASHRAE 110
- ANSI Z9.5
- SEFA 8

5', 6' and 8' models with 35.5" exterior depth include:

- Left-side mounted waste chute. **Bags not included.** Minimum bag size required: 10.0" x 16.0"

Required accessories (not included):

- Remote blower or FilterMate Portable Exhauster(s). See pages 24-26 and 31
- Work surface. See page 29

- Supporting base
- Ductwork. See pages 30-31 and back cover

Optional accessories (see pages 29-31 and back cover):

- Guardian Airflow Monitors
- Fluorescent Task Lights
- Utility Shelves, Bottle Holder and Tissue Holder
- Exhaust Transition Adapters
- Waste Chute Stopper
- Waste Chute Bags. Contact your laboratory supply dealer

Nominal Width	Height	Sash Opening Height	Total Exhaust CFM and Static Pressure (w.g.)					
			100 fpm	s.p.	80 fpm	s.p.	60 fpm	s.p.
2 Feet	Std.	8"	120	0.05"	95	0.03"	70	0.02"
2 Feet	Tall	10"	150	0.08"	120	0.05"	90	0.03"
3 Feet	Std.	8"	185	0.10"	145	0.06"	110	0.04"
3 Feet	Tall	10"	230	0.15"	185	0.10"	140	0.06"
4 Feet	Std.	8"	250	0.16"	200	0.10"	150	0.06"
4 Feet	Tall	10"	310	0.24"	250	0.16"	185	0.09"
5 Feet	Std.	8"	315	0.23"	250	0.15***	190	0.08"
5 Feet	Tall	12"	480	0.54"	385	0.35***	290	0.20"
6 Feet	Std.	8"	380	0.32"	305	0.21***	230	0.12"
6 Feet	Tall	12"	580	0.75"	465	0.48***	350	0.27"
8 Feet	Std.	8"	510	0.18"	410	0.12"†	310	0.07"
8 Feet	Tall	12"	775	0.42"	620	0.27"†	465	0.15"

* Labconco exclusive feature

* U.S. Patent No. 6,461,233

**Static pressure when one center exhaust opening is used.

†Static pressure when two outer exhaust openings are used. Requires "T" Connector 3981600, not included. Contact Labconco.

††Contact Labconco for more information.

Protector® XVS™ Ventilation Stations

Ordering Information & Dimensional Data

Catalog Number	Nominal Width	Overall Height (E) in./cm	Overall Depth (H) in./cm	Overall Width (A) in./cm	(B) in./cm	(C) in./cm	(D) in./cm	(F) in./cm	(G) in./cm	(I) in./cm	(J) in./cm	(K) in./cm	Shipping Weight lbs./kg
4862010	2 Feet	22.8/57.9	29.0/73.7	24.0/61.0	12.0/30.5	21.6/54.9	28.6/72.6	22.3/56.6	19.0/48.3	23.4/59.4	8.0/20.3	—	105/48
4862030	2 Feet	32.0/81.3	29.0/73.7	24.0/61.0	12.0/30.5	21.6/54.9	37.8/96.0	31.5/80.0	27.7/70.4	23.4/59.4	10.0/25.4	—	135/61
4863010	3 Feet	22.8/57.9	29.0/73.7	36.0/91.4	18.0/45.7	33.6/85.3	28.6/72.6	22.3/56.6	19.0/48.3	23.4/59.4	8.0/20.3	—	135/61
4863030	3 Feet	32.0/81.3	29.0/73.7	36.0/91.4	18.0/45.7	33.6/85.3	37.8/96.0	31.5/80.0	27.7/70.4	23.4/59.4	10.0/25.4	—	160/73
4864010	4 Feet	22.8/57.9	29.0/73.7	48.0/121.9	24.0/61.0	45.6/115.8	28.6/72.6	22.3/56.6	19.0/48.3	23.4/59.4	8.0/20.3	—	160/73
4864030	4 Feet	32.0/81.3	29.0/73.7	48.0/121.9	24.0/61.0	45.6/115.8	37.8/96.0	31.5/80.0	27.7/70.4	23.4/59.4	10.0/25.4	—	185/84
4865010	5 Feet	22.8/57.9	29.0/73.7	60.0/152.4	30.0/76.2	57.6/146.3	28.6/72.6	22.3/56.6	19.0/48.3	23.4/59.4	8.0/20.3	10.0/25.4	290/132
4865030	5 Feet	32.0/81.3	29.0/73.7	60.0/152.4	30.0/76.2	57.6/146.3	37.8/96.0	31.5/80.0	27.7/70.4	23.4/59.4	12.0/30.5	10.0/25.4	340/154
4865060	5 Feet*	32.0/81.3	35.5/90.2	60.0/152.4	30.0/76.2	57.6/146.3	37.8/96.0	31.5/80.0	27.7/70.4	30.0/76.2	12.0/30.5	10.0/25.4	380/172
4866010	6 Feet	22.8/57.9	29.0/73.7	72.0/182.9	36.0/91.4	69.6/176.8	28.6/72.6	22.3/56.6	19.0/48.3	23.4/59.4	8.0/20.3	10.0/25.4	340/154
4866030	6 Feet	32.0/81.3	29.0/73.7	72.0/182.9	36.0/91.4	69.6/176.8	37.8/96.0	31.5/80.0	27.7/70.4	23.4/59.4	12.0/30.5	10.0/25.4	395/179
4866060	6 Feet*	32.0/81.3	35.5/90.2	72.0/182.9	36.0/91.4	69.6/176.8	37.8/96.0	31.5/80.0	27.7/70.4	30.0/76.2	12.0/30.5	10.0/25.4	440/220
4868010	8 Feet	22.8/57.9	29.0/73.7	96.0/243.8	48.0/121.9	93.6/237.7	26.6/72.6	22.3/56.6	19.0/48.3	23.4/59.4	8.0/20.3	24.0/61.0	455/206
4868030	8 Feet	32.0/81.3	29.0/73.7	96.0/243.8	48.0/121.9	93.6/237.7	37.8/96.0	31.5/80.0	27.7/70.4	23.4/59.4	12.0/30.5	24.0/61.0	520/236
4868060	8 Feet*	32.0/81.3	35.5/90.2	96.0/243.8	48.0/121.9	93.6/237.7	37.8/96.0	31.5/80.0	27.7/70.4	30.0/76.2	12.0/30.5	24.0/61.0	580/263

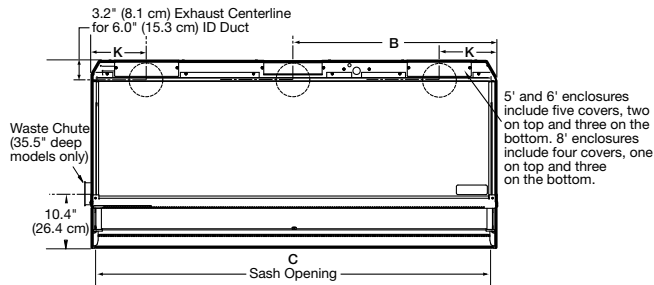

TOP
(5', 6', 8' Models)

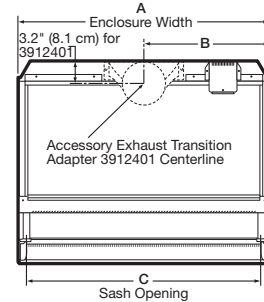

TOP
(2', 3', 4' Models)

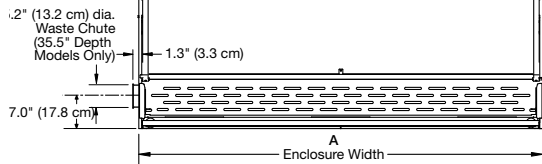

FRONT
(5', 6', 8' Models)

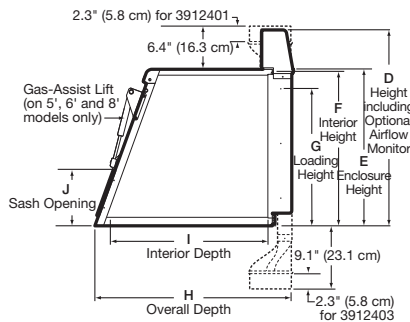

SIDE (All Models)

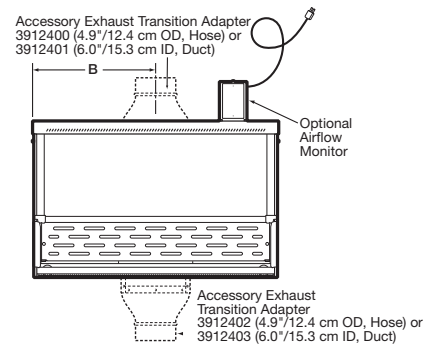

FRONT
(2', 3', 4' Models)

*Includes waste chute
Contact Labconco at (800) 821-5525 or (816) 333-8811 or visit labconco.com for detailed AutoCAD drawings.

Protector® Demonstration Hoods

Specifications



Protector Demonstration Hood System 3945001

Protector Demonstration Hoods are low profile, light-duty fume hoods designed to provide 360° of close observation of procedures during educational demonstrations.

All models feature:

- * Deep 23" interior easily accommodates a variety of apparatus
- * Patented* Clean-Sweep™ air foil allows air to sweep the work surface for maximum containment. Airflow openings pull inflow air from under the air foil so that clean air continually flows through the air foil creating a constant barrier of protection from contaminants
- * Upper containment sash foil bleeds air into the enclosure to direct concentrations of contaminants away from the operator's breathing zone*
- * Upper dilution air supply introduces room air at the top of the sash to dilute concentrations in the upper chamber and bathes the back of the sash with clean air
- * Clear rear baffle directs air streams to the back of the interior for removal through the exhaust connection. The baffle may be pivoted downward for cleaning

- * Side-entry air foils allow air to sweep across the interior glass surfaces to enhance containment
- Sturdy glacier white and gray powder-coated aluminum frame
- Tempered safety glass front sash, sides, rear baffle and top offer excellent 360° visibility, ambient light and protection. Glass provides better fire, scratch and corrosion resistance than acrylic
- 8" high sash opening limits exhaust demand, conserves costly tempered room air and requires a smaller remote blower than most fume hoods. Tall models, 32.0" high, have a 10" high sash opening
- * Ergonomic angled sash allows a closer view, reduces glare and provides a more comfortable operating position than vertical sashes. Models, 22.8" high, have a 20° angle; models, 32.0" high, have a 14° angle. The hinged sash pivots upward and locks to a loading height of 19.0" or 27.7" depending on the model
- Lower exhaust tissue screen
- Two utility ports with iris openings allow passage of tubing, electrical cords and interface cables from inside to back exterior for connection to services
- Flexible exhaust options. 2.0" x 10.0" rectangular exhaust collars on the top and bottom allow the Protector Demonstration Hood to be connected to ductwork for exhausting to the outside or to a FilterMate Portable Exhauster for filtered removal of fumes and/or particulates. Using the bottom exhaust collar keeps ductwork hidden, maximizing room visibility

Standards conformance & regulations:

- SEFA 1
- Modified ASHRAE 110
- ANSI Z9.5
- UL 61010-1 (115V models)
- CAN/CSA C22.2 No. 61010.1 (115V models)

- CE Conformity Marking (230V models)
- SEFA 8

System Models 3945000, 3945001, 3945020 & 3545021 also include:

- Cart of glacier white powder-coated tubular steel with black 1" thick solid epoxy dished work surface, handle bar, bottom shelf and 4" diameter toe-locking casters
- FilterMate Portable Exhauster designed for use with two Carbon Filters or one Carbon Filter and one HEPA Filter (Filters are not included. See page 26 for ordering information.) Includes 8 feet of 5" ID flexible gray polypropylene hose, two clamps, a 4.9" OD Lower Transition Adapter for connection to the bottom of the Protector Demonstration Hood, and an IEC 3-wire electrical cord with plug

Models 3944300 & 3944301 require:

- Connection to a remote blower, house exhaust or FilterMate Portable Exhauster. See pages 24-26 for FilterMate. See pages 30-31 and back cover for Remote Blowers and ductwork
- Work surface and supporting base. See page 29 for Cart. See page 29 for work surface

Accessories include (see pages 29-31 and back cover):

- Fluorescent Task Lights
- Exhaust Transition Adapters
- Exhaust Dampers
- Guardian Airflow Monitors
- Cart
- Remote Blowers



Nominal Width	Overall Height	Sash Opening Height	Total Exhaust CFM and Static Pressure					
			100 fpm	s.p.	80 fpm	s.p.	60 fpm	s.p.
3 Feet	22.8"	8"	185	0.10"	145	0.06"	110	0.04"
3 Feet	32.0"	10"	230**	0.15"	185	0.10"	140	0.06"

* Labconco exclusive feature

*U.S. Patent No. 6,461,233

**FilterMate Portable Exhauster with two filters provides up to 220 CFM and with single filter provides up to 270 CFM.

Protector® Demonstration Hoods

Ordering Information & Dimensional Data

Catalog Number	Nominal Width	Electrical Requirements	Enclosure Height	Shipping Weight
Protector Demonstration Hoods				
3944300	3 Feet	Not Applicable	22.8"	75 lbs. (34 kg)
3944301	3 Feet	Not Applicable	32.0"	85 lbs. (39 kg)
Protector Demonstration Hood Systems—include Cart with Work Surface, Lower Transition Adapter and FilterMate Portable Exhauster for use with two Carbon Filters or one Carbon Filter and one HEPA Filter in any combination.*				
3945000	3 Feet	115V, 60 Hz, 10A	22.8"	125 lbs. (57 kg)
3945001	3 Feet	115V, 60 Hz, 10A	32.0"	135 lbs. (61 kg)
3945020**	3 Feet	230V, 50/60 Hz, 5A	22.8"	125 lbs. (57 kg)
3945021**	3 Feet	230V, 50/60 Hz, 5A	32.0"	135 lbs. (61 kg)

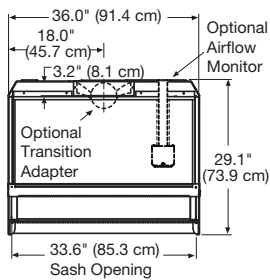

TOP
(3944300 & 3944301)

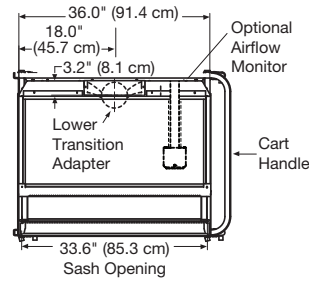

TOP
(3945000, 3945001,
3945020 & 3945021)

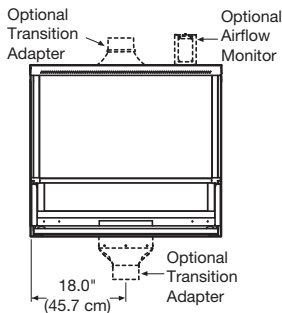

FRONT
(3944300 & 3944301)

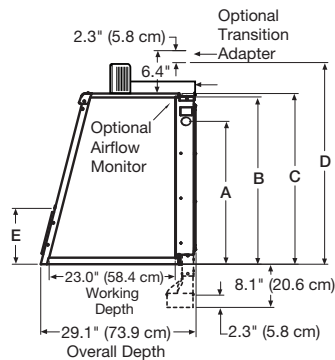

SIDE
(3944300 & 3944301)

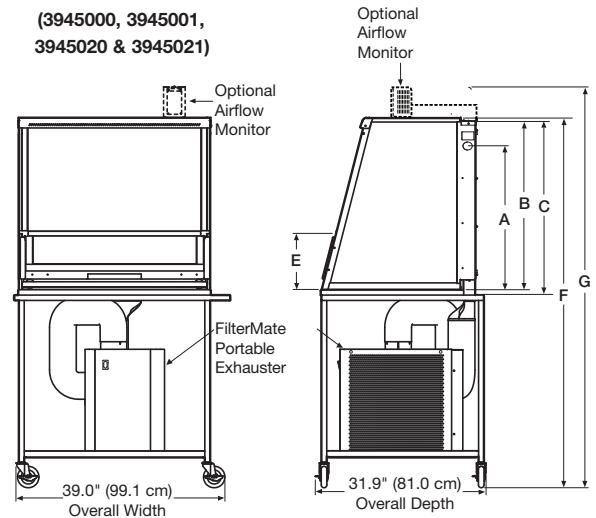

FRONT
(3945000, 3945001,
3945020 & 3945021)

SIDE
(3945000, 3945001,
3945020 & 3945021)

Catalog Number	Loading Height (A)	Interior Height (B)	Enclosure Height (C)	Height w/ Monitor (D)	Sash Opening (E)	Height w/ Cart (F)	Height w/ Cart & Monitor (G)
3944300, 3945000 & 3945020	19.0" (48.3 cm)	22.3" (56.4 cm)	22.8" (57.9 cm)	28.6" (72.6 cm)	8.0" (20.3 cm)	58.8" (149.4 cm)	64.6" (164.1 cm)
3944301, 3945001 & 3945021	27.7" (70.4 cm)	31.5" (80.0 cm)	32.0" (81.3 cm)	37.9" (96.3 cm)	10.0" (25.4 cm)	68.0" (172.7 cm)	73.9" (187.7 cm)

*Filters are required but not included. See page 26 for ordering information.

**International electrical configuration

FilterMate™ Portable Exhausters

Specifications



FilterMate Portable Exhauster 3970000. Includes HEPA filter.



FilterMate Portable Exhauster 3970001. **Requires carbon filter (not included).**



FilterMate Portable Exhauster 3970002. Includes HEPA filter and thimble connection. **Requires ducting to outside.**



FilterMate Portable Exhauster 3970003. Includes HEPA filter. **Requires carbon filter (not included).**

An accessory for the Protector XVS Ventilation Station, Protector Demonstration Hood, Protector Work Station and XPert® Balance Enclosure, the FilterMate uses a HEPA filter, carbon filter or a combination of both filters to remove hazardous powders, particulates or vapors from the exhaust air stream and return filtered air to the environment.

All models feature:

- Compact, corrosion-resistant housing of glacier white and light gray powder-coated steel with rubber feet
- * Variable-speed, non-sparking motorized impeller
- Quiet operation. Oversized HEPA filter, efficient impeller and perforated exhaust cover work together to provide lower system exhaust velocity and noise pressure levels

Exhaust CFM	Noise Pressure dB(A)
100	45-47
150	51-54
200	56-61
250	63-65

- * Inherently safe design. A negative pressure plenum surrounds the positive pressure impeller so that if a leak occurs, the unfiltered air is captured and refiltered
- * Capable of efficiently filtering up to 250 CFM for HEPA or carbon filtration; up to 200 CFM for combination HEPA/carbon filtration (60-100 fpm depending on enclosure model)
- Front-mounted rocker switch to control power to the blower
- * Rear-mounted, auxiliary electrical outlet that may be connected to an airflow monitor or other user-supplied accessories
- * Only one FilterMate is required for all 2', 3' and 4' wide enclosures. Multiple FilterMates may be used for 5', 6' and 8' wide enclosures
- * Included: 8 feet of 5.0" ID flexible gray polypropylene hose, two clamps and a 4.9" OD Upper Transition Adapter for connection to the top of the Protector XVS Ventilation Station or Protector Demonstration Hood. Models 3970004 and 3970024 include a 4.9" OD Lower Transition Adapter instead of the Upper Transition Adapter

- * Labconco exclusive feature

- 6.5' IEC three-wire electrical cord with plug (115V models)
- 9' IEC three-wire electrical cord. **An electrical plug is required (230V models)**

Standards conformance & regulations:

- UL 61010-1
- CAN/CSA C22.2 No. 61010.1
- CE Conformity Marking (230V models)

Models 3970000, 3970020, 3970002, 3970022, 3970003 and 3970023 feature:

- HEPA filter, 99.99% efficient on particulates 0.3 micron in size
- * True bag-in/bag-out filter disposal system for safely removing and replacing the filter without detaching the hose. The HEPA filter may be easily accessed by removing the exhaust cover for field leak testing by a certified technician

Models 3970002 and 3970022 feature:

- 6.1" ID thimble connection from the FilterMate to an existing house exhaust system for added safety

Models 3970001, 3970021, 3970003 and 3970023 require one each and Models 3970004 and 3970024 require two each (not included):

- Carbon Filter. Organic Vapor, Formaldehyde or Ammonia Filters are offered. See page 26

Optional Accessories:

- Replacement HEPA Filter. See page 26
- Replacement Bag-In/Bag-Out Bag. See page 26
- Flexible Hose. See page 30
- Thimble Connection. See page 30



FilterMate™ Portable Exhausters

Ordering Information & Dimensional Data

Catalog Number	Filter Usage	Overall Dimensions	Electrical Requirements	Airflow Potential	Exhaust Connection	Shipping Weight
3970000	HEPA included	14.0" w x 23.0" d x 22.7" h	115V, 60 Hz	250 CFM (60-100 fpm)	None. Room exhaust.	50 lbs. (23 kg)
3970020*	HEPA included	14.0" w x 23.0" d x 22.7" h	230V, 50 Hz	250 CFM (60-100 fpm)	None. Room exhaust.	50 lbs. (23 kg)
3970001	Carbon required†	14.0" w x 23.0" d x 22.7" h	115V, 60 Hz	250 CFM (60-100 fpm)	None. Room exhaust.	48 lbs. (22 kg)
3970021*	Carbon required†	14.0" w x 23.0" d x 22.7" h	230V, 50 Hz	250 CFM (60-100 fpm)	None. Room exhaust.	48 lbs. (22 kg)
3970002	HEPA included	18.6" w x 23.0" d x 24.7" h	115V, 60 Hz	250 CFM (60-100 fpm)	6.1" ID Thimble to outside	54 lbs. (25 kg)
3970022*	HEPA included	18.6" w x 23.0" d x 24.7" h	230V, 50 Hz	250 CFM (60-100 fpm)	6.1" ID Thimble to outside	54 lbs. (25 kg)
3970003	HEPA included†† Carbon required†	14.9" w x 23.0" d x 22.7" h	115V, 60 Hz	200 CFM (60-100 fpm)**	None. Room exhaust.	52 lbs. (24 kg)
3970023*	HEPA included†† Carbon required†	14.9" w x 23.0" d x 22.7" h	230V, 50 Hz	200 CFM (60-100 fpm)**	None. Room exhaust.	52 lbs. (24 kg)
3970004	Two carbon required	14.9" w x 23.0" d x 22.7" h	115V, 60 Hz	200 CFM (60-100 fpm)**	None. Room exhaust.	52 lbs. (24 kg)
3970024*	Two carbon required	14.9" w x 23.0" d x 22.7" h	230V, 50 Hz	200 CFM (60-100 fpm)**	None. Room exhaust.	52 lbs. (24 kg)

Models 3970000, 3970001, 3970020 & 3970021

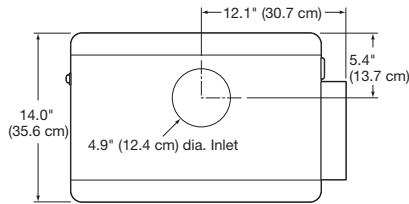

TOP

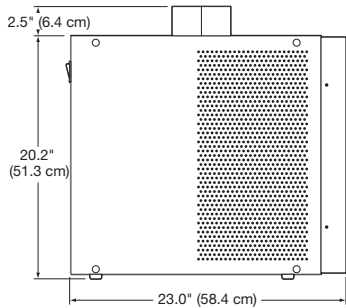

SIDE

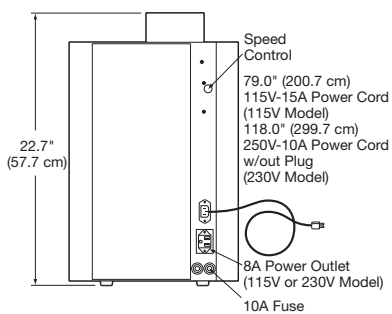

REAR

Models 3970002 & 3970021

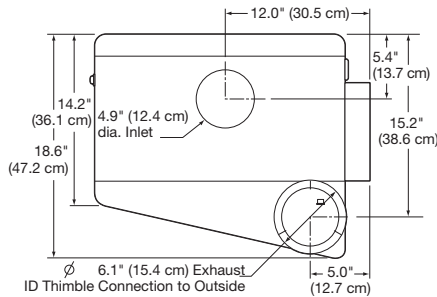

TOP

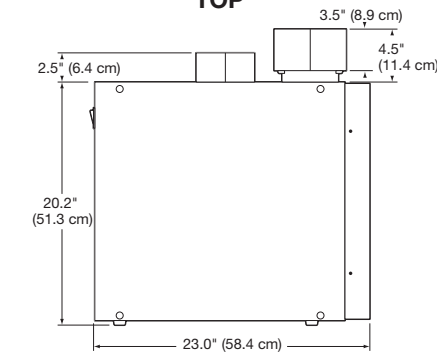

SIDE

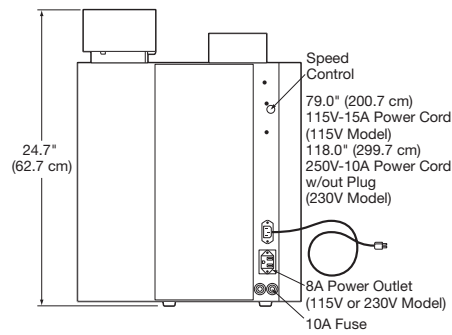

REAR

Models 3970003 & 3970023

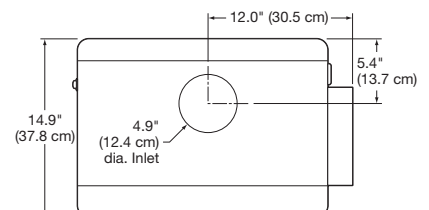

TOP

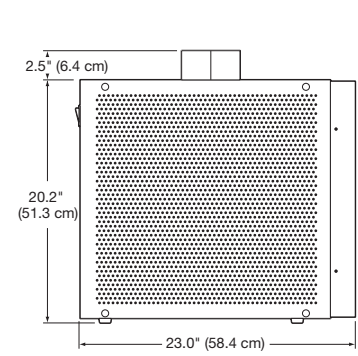

SIDE

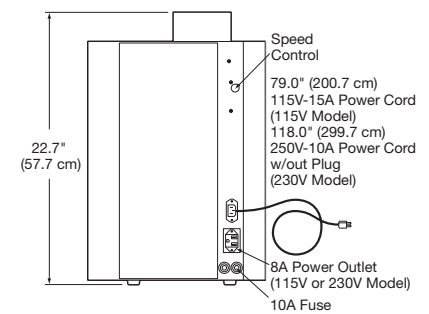

REAR

*International electrical configuration
**60-80 fpm on 4' enclosure.

†Carbon Filter is not included.
††HEPA filter may be removed and substituted with a second carbon filter.

FilterMate™ Portable Exhausters

Carbon & HEPA Filters

The Application Matrix provides examples of appropriate uses for carbon and/or HEPA filters expended in the FilterMate Portable Exhauster. Whether or not any ductless enclosure is appropriate for your application requires consideration of factors such as the time-weighted exposure limits of your materials. Using Labconco's exclusive chemical assessment program, our technical specialists can help you determine if a Labconco ductless enclosure is the right ventilation product for your application and, if so, estimate filter life. To begin the

process, please complete the **Chemical Usage Assessment Form** available at labconco.com or call us at **(800) 821-5525** or **(816) 333-8811**.

Carbon and HEPA Filters are available in a variety of types and, in some cases, may be used in carbon/HEPA filter combination. An online **Chemical Guide**, available at labconco.com, allows you to search individual chemicals to determine their suitability for use with a carbon-filtered enclosure.

- **Organic Filters** are suitable for vapors from solvents including acetone, ethyl acetate, toluene and xylene as well as light vapors from hydrochloric and nitric acid
- **Formaldehyde Filters** are suitable for vapors from formaldehyde, formalin and gluteraldehyde
- **Ammonia Filters** are suitable for ammonia and low molecular weight amines
- **HEPA Filters**, 99.99% efficient, are suitable for removing particulates such as powders and pollen. **They should not be used to capture chemical vapors**

Application Matrix

Filter Type Configuration	FilterMate & Protector Work Station			FilterMate	
	Organic	Ammonia	Formaldehyde	Carbon & HEPA*	HEPA
Asbestos handling					•
Combination dry and liquid chemicals				•	
Endoscopy instrument cleaning			•		
Histology/cytology/pathology tissue staining, coverslipping	•			•	
Histology/pathology	•			•	
Hormone research				•	•
Non-biohazardous microbiological samples with trace chemicals**				•	
Particulates in conjunction with chemical agents				•	
Pathology/tissue grossing			•	•	
Photo-engraving		•			
Plastics production		•			
Pollen handling				•	•
Soldering				•	•
Solvent cleaning	•				
Solvent welding/gluing	•				
Weighing/mixing chemical/drug powders				•	•

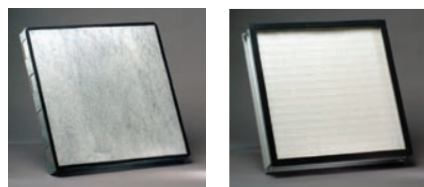

Carbon and HEPA Filters and Accessories for use with FilterMate Portable Exhausters. A HEPA Filter and Bag-In/Bag-Out Bag are included with FilterMate Portable Exhausters designed for use with HEPA filters. One or two Carbon Filters are required for operation with FilterMate Portable Exhausters designed for use with carbon filters.

Catalog Number	Description	Shipping Weight
3923400	Organic Carbon Filter , Type AC. Contains 12 pounds of granular activated carbon media.	14 lbs. (6 kg)
3923401	Formaldehyde Carbon Filter , Type ST-1. Contains a minimum of 14 pounds of impregnated carbon media.	17 lbs. (8 kg)
3923402	Ammonia Carbon Filter , Type AC. Contains a minimum of 16 pounds of impregnated carbon media.	21 lbs. (10 kg)
3707900	Replacement HEPA Filter , 99.99% efficient on particles 0.3 micron in size	10 lbs. (5 kg)
3776002	Replacement Bag-In/Bag-Out Bag to ensure containment of particulate matter during HEPA filter changing	1 lb. (0.5 kg)
1968800	Orange Cinching Strap for Bag-In/Bag-Out Bag	1 lb. (0.5 kg)

Labconco strongly recommends ordering and keeping an extra set of filters to have readily available when filters become saturated and require replacement. Sign up for the Filter Reminder Email Service at labconco.com.

*Carbon filter type varies based on application.

**The FilterMate Portable Exhauster is not designed to accommodate changing and disposing of biohazardous filters and materials and, therefore, should not be used as part of a biosafety enclosure.

Canopy Hoods

Specifications & Ordering Information



The Canopy Hood is specifically **designed to vent non-toxic materials such as heat, steam and odors** from large or bulky apparatus such as ovens, steam baths and autoclaves. The hood may be installed on a wall or suspended from the ceiling for peninsular and corner locations. **For most efficient performance, the hood should be installed no more than 12" above the equipment to be ventilated.** Coupled with a blower and ductwork, the Canopy Hood can operate at a wide range of exhaust rates.

Features:

- Glacier white powder-coated steel construction
- Integral baffle
- Fully assembled
- Include mounting hardware for installation on wall or suspended from ceiling. **Threaded rod is required for suspension from ceiling**

Required accessories (not included):

- Remote blower
- Ductwork

Ordering Information

Catalog Number	Nominal Width	Shipping Weight
4799000	4 Feet	140 lbs. (64 kg)
7099000	6 Feet	205 lbs. (93 kg)

4' Canopy Hood 4799000

CFM at Static Pressure — Inches H ₂ O							
0.12"	0.19"	0.22"	0.36"	0.39"	0.73"	2.45"	
325	450	488	650	675	975	1950	

6' Canopy Hood 7099000

CFM at Static Pressure — Inches H ₂ O							
0.17"	0.24"	0.31"	0.45"	0.49"	0.89"	2.50"	
425	550	638	825	850	1275	2550	

Dimensional Data

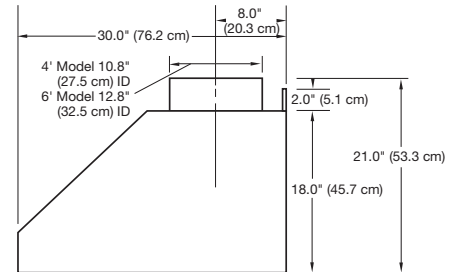

SIDE

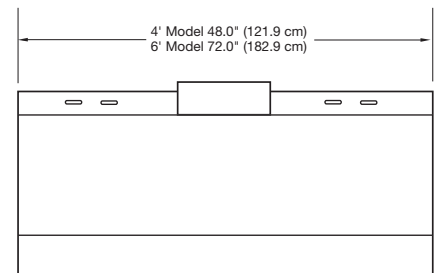

FRONT

Flat Work Surfaces & Accessories

Flat Solid Epoxy Work Surfaces

For Use with Labconco Enclosures including Fiberglass 30 and Basic Laboratory Hoods*

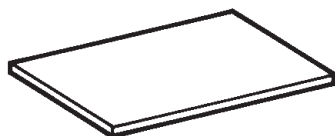

Catalog Number	Description	Shipping Weight
4882806	30" w x 30" d x 1.25" thick, no cutouts	86 lbs. (39 kg)
4882805	36" w x 30" d x 1.25" thick, no cutouts	90 lbs. (41 kg)
4882803	48" w x 30" d x 1.25" thick, no cutouts	110 lbs. (50 kg)
4882804	72" w x 30" d x 1.25" thick, no cutouts	205 lbs. (93 kg)

SpillStopper™ & Flat Work Surface Accessories

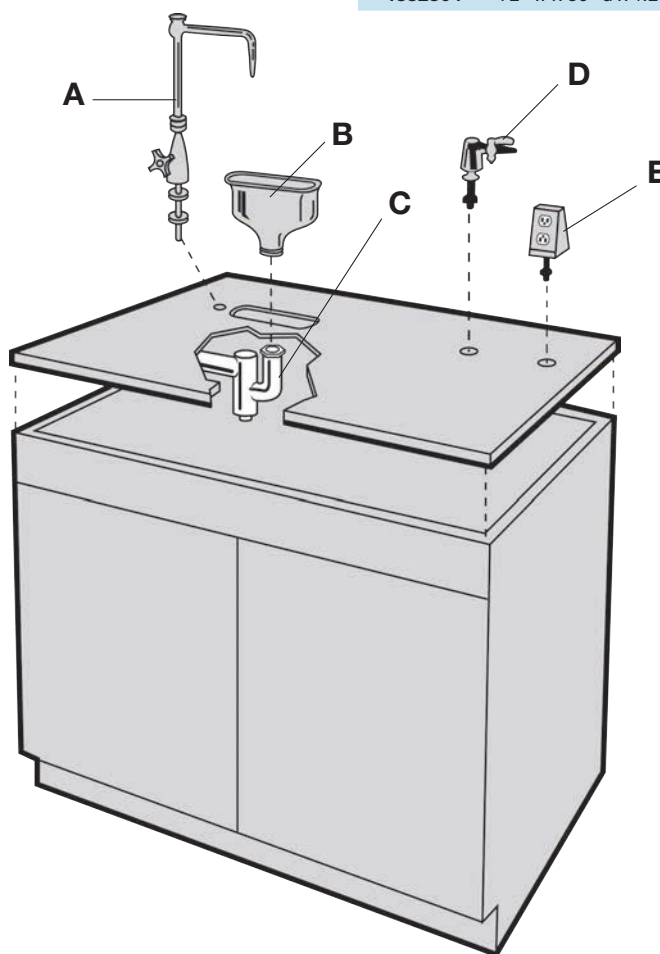

- (A) **4005100—Cold Water Faucet with Rigid Gooseneck.** Factory-drilled mounting hole in work surface is required. Shipping weight 4.0 lbs. (1.8 kg)
- (A) **4005900—Cold Water Faucet with Rigid Gooseneck and Vacuum Breaker.** Factory-drilled mounting hole in work surface is required. Shipping weight 4.0 lbs. (1.8 kg)
- (B) **4005200—Oval Polypropylene Cupsink.** Mounts in work surface with cupsink cutout. 3.0" x 6.0". 1.5" NPSM** thread. Shipping weight 4.0 lbs. (1.8 kg)
4005201—Cupsink Cover. Black solid epoxy resin cover for oval cupsink cutout. Provides a continuous work surface when a cupsink is not in use. 7.4" wide x 4.4" deep x 0.3" thick (18.8 x 11.2 x 0.8 cm). Shipping weight 2.0 lbs. (0.9 kg)
- (C) **1432600—Trap, PVC.** 1.5" diameter drum with coupling nut. For use with cupsink. Shipping weight 10 lbs. (5 kg)
1361100—Sepia Bronze-Coated Cold and Hot Water Mixing Faucet with Swivel Gooseneck. Not shown. Factory-drilled mounting hole in work surface is required. Shipping weight 4.0 lbs. (1.8 kg)
1361200—Chrome-Plated Cold and Hot Water Mixing Faucet with Swivel Gooseneck. Not shown. Factory-drilled mounting hole in work surface is required. Shipping weight 4.0 lbs. (1.8 kg)
- (D) **4005000—Service Fixture.** Specify air, gas or vacuum. Factory-drilled mounting hole in work surface is required. Shipping weight 4.0 lbs. (1.8 kg)
- (E) **4005800—Electrical Receptacle.** Pedestal-type, 115 volt, 15 amp duplex. Factory-drilled mounting hole in work surface is required. Shipping weight 4.0 lbs. (1.8 kg)

*Basic Hoods are not as wide or as deep as the work surfaces that support them.

**National Pipe Straight Mechanical

Accessories

Protector® XVS Ventilation Stations & Protector® Demonstration Hoods



Solid Epoxy Work Surfaces. Black work surfaces are contoured to fit the dimensions of Protector XVS Ventilation Stations and Protector Demonstration Hoods and dished to contain spills. One inch thick molded solid epoxy is chemical resistant and fire proof.

Catalog Number	Dimensions	For Use With	Shipping Weight
3908400	24.0" w x 26.7" d	2' Protector XVS	48 lbs. (22 kg)
3908401	36.0" w x 26.7" d	3' Protector XVS, Protector Demonstration Hoods	72 lbs. (33 kg)
3908402	48.0" w x 26.7" d	4' Protector XVS	96 lbs. (44 kg)
3908406	60.0" w x 26.7" d	5' Protector XVS - 29.0" deep models	120 lbs. (54 kg)
3908407	72.0" w x 26.7" d	6' Protector XVS - 29.0" deep models	144 lbs. (65 kg)
3908408	96.0" w x 26.7" d	8' Protector XVS - 29.0" deep models	192 lbs. (88 kg)
3908409	60.0" w x 35.5" d	5' Protector XVS - 35.5" deep models	160 lbs. (72 kg)
3908410	72.0" w x 35.5" d	6' Protector XVS - 35.5" deep models	192 lbs. (88 kg)
3908411	96.0" w x 35.5" d	8' Protector XVS - 35.5" deep models	255 lbs. (115 kg)



Stainless Steel Work Surfaces. Type 304 stainless steel work surfaces are 0.8" thick, have a one inch deep front spill trough and fit dimensions of the Protector XVS Ventilation Stations. Available in 5', 6' and 8' widths.

Catalog Number	Dimensions	For Use With	Shipping Weight
3975500	60.0" w x 26.7" d	5' Protector XVS - 29.0" deep models	140 lbs. (64 kg)
3975501	60.0" w x 35.5" d	5' Protector XVS - 35.5" deep models	180 lbs. (82 kg)
3975600	72.0" w x 26.7" d	6' Protector XVS - 29.0" deep models	170 lbs. (77 kg)
3975601	72.0" w x 35.5" d	6' Protector XVS - 35.5" deep models	220 lbs. (100 kg)
3975800	96.0" w x 26.7" d	8' Protector XVS - 29.0" deep models	240 lbs. (109 kg)
3975801	96.0" w x 35.5" d	8' Protector XVS - 35.5" deep models	290 lbs. (132 kg)



8026000—Cart for Protector Demonstration Hoods. Provides mobile support for Protector Demonstration Hoods and 3' Protector XVS Ventilation Stations. Glacier white powder-coated tubular steel with black 1" thick solid epoxy dished work surface, handle bar, bottom shelf and 4" diameter toe-locking casters. Supports loads up to 400 pounds. Cart is included with Protector Demonstration Hood Systems 3945000, 3945001, 3945020 and 3945021. Dimensions: 39.0" w x 31.9" d x 36.0" h. Shipping weight 50 lbs. (23 kg)



Fluorescent Task Lights. For use with Protector XVS Ventilations Stations and Protector Demonstration Hoods. May be placed atop the enclosure to enhance illumination of the interior. Include auxiliary electrical receptacle with switch for connection of accessories such as a printer or airflow monitor.

Catalog Number	Description	Shipping Weight
3909200	115V, 60 Hz, 10A. Includes IEC, three-wire cord with plug.	15 lbs. (7 kg)
3909201*	230V, 50 Hz, 10A. Includes IEC, three-wire cord. Plug is required (not included).	15 lbs. (7 kg)



5248300—Waste Chute Stopper. For use with 5', 6' and 8' Protector XVS Ventilation Stations, 35.5" deep, with waste chute. When waste chute is not in use, the stopper helps prevents contaminants from escaping the enclosure through the side wall. Solid rubber. 5" diameter. Shipping weight 1.0 lb. (0.5 kg)

*International electrical configuration

Accessories

Protector® XVS Ventilation Stations & Protector® Demonstration Hoods

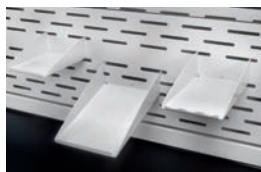

3925000—Utility Shelves. For use with Protector XVS Ventilation Stations. Three shelves attach to the rear baffle perforations to hold items such as a balance printer, utensils and other miscellaneous supplies. The utensil shelf has a scalloped front edge to support scalpels, forceps and other items. Powder-coated steel. Shipping weight 5.0 lbs. (2.3 kg)



3927700—Bottle Holder. For use with Protector XVS Ventilation Stations. Attaches to the rear baffle perforations to hold a squirt bottle or other round container. Powder-coated steel. 3" diameter opening. Shipping weight 1.0 lb. (0.5 kg)



3927800—Tissue Holder. For use with Protector XVS Ventilation Stations. Attaches to the rear baffle perforations to hold tissue wipers in the upside down position. Opening in the bottom of the holder permits wipers to be dispensed from the bottom. Powder-coated steel. Shipping weight 1.0 lb. (0.5 kg)

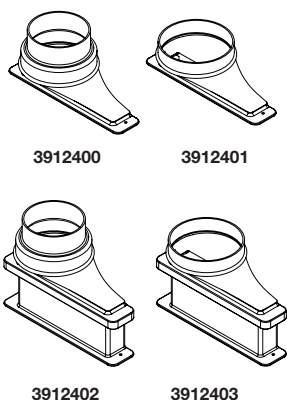

Exhaust Transition Adapters. For use with Protector XVS Ventilation Stations and Protector Demonstration Hoods designed for outside ducting or connected to the FilterMate Portable Exhauster. Molded polyethylene.

Catalog Number	Description	Shipping Weight
3912400	Upper Exhaust Transition Adapter , 2.0" x 10.0" rectangular to 5.0" diameter round for connection to 5" ID hose. Included with FilterMate Portable Exhauster.	5.0 lbs. (2.3 kg)
3912401	Upper Exhaust Transition Adapter , 2.0" x 10.0" rectangular to 6.0" diameter round for connection to 6" OD duct.	5.0 lbs. (2.3 kg)
3912402	Lower Exhaust Transition Adapter , 2.0" x 10.0" rectangular to 5.0" diameter round for connection to 5" ID hose. Included with Protector Demonstration Hood System.	5.0 lbs. (2.3 kg)
3912403	Lower Exhaust Transition Adapter , 2.0" x 10.0" rectangular to 6.0" diameter round for connection to 6" OD duct.	5.0 lbs. (2.3 kg)

Flexible Hose for FilterMate Portable Exhauster. For use with the FilterMate Portable Exhauster instead of the flexible polypropylene hose included. 8' length. Include two clamps.

⚠WARNING: Cancer - P65Warnings.ca.gov (California only)

Catalog Number	Description	Shipping Weight
3927500	5" ID , clear urethane, smooth bore with white helix, static dissipative, suitable for pharmaceutical and clean room applications.	3.0 lbs. (1.4 kg)
3927600	6" ID , black thermoplastic rubber hose with 6.1" ID cuffs, suitable for pharmaceutical and clean room applications. May be used to duct to the outside. Requires 3927400 Adapter, sold separately. See page 31.	3.0 lbs. (1.4 kg)

3913600—Thimble Connection Kit. For retrofitting FilterMate Portable Exhausters 3970000, 3970020, 3970001, 3970004 and 3970024. Included with FilterMate Portable Exhausters 3970002 and 3970022. Shipping weight 10 lbs. (4 kg)

Accessories

Protector® XVS Ventilation Stations & Protector® Demonstration Hoods

Ductwork

Catalog Number	Description	Equivalent Resistance [†]	Shipping Weight
4708600	Thermoplastic Duct, 6.625" OD, 6.25" ID, 10' length	10'	25 lbs. (11 kg)
4708700	90° PVC Elbow, 6" nominal diameter, has belled end connections to directly receive Thermoplastic Duct or Male Duct Coupling	12'	1.0 lb. (0.5 kg)
4708900	Female PVC Duct Coupling, 6" nominal diameter, connects two sections of Thermoplastic Duct	0'	4.0 lbs. (1.8 kg)
3924000	Manual Exhaust Damper, powder-coated steel, 6" nominal diameter	1'	1.0 lb. (0.5 kg)
4724200	Manual Exhaust Damper, PVC, 6" nominal diameter	1'	1.0 lb. (0.5 kg)
4861800	Flexible Duct Connection, 7" nominal diameter, for use with 6" nominal diameter duct △WARNING: Cancer - P65Warnings.ca.gov (California only)	1'	8.0 lbs. (3.6 kg)
3927400	Adapter, 5" round to 6" round, for use with 3927600 Hose	1'	1.0 lb. (0.5 kg)
4861700	Blower Transition Adapter, 4.25" x 7.75" rectangle to 6" diameter round	1'	3.0 lbs. (1.4 kg)
4722200	Zero Pressure Weathercap, 6" nominal diameter, fits atop Thermoplastic Duct	5'	20 lbs. (9 kg)

Remote Blowers. Required when ducting the Protector XVS Ventilation Station or Protector Demonstration Hood to the outside. Direct drive blower has a 1/4 hp TEFC-type motor and overcomes external static pressure of 0.5" at 420 CFM. Housing and impeller are corrosion-resistant, phenolic-coated steel. Blower inlet is 5.9" OD and is sized to accept 6" nominal diameter PVC duct. Blower outlet is 4.25" x 7.4" OD. Dimensions: 14.6" w x 13.5" d x 13.25" high.



Catalog Number	Electrical Requirements	Shipping Weight
4863500	115V, 60 Hz, 4.4A	35 lbs. (16 kg)
4863501*	115/230V, 50 Hz, 5.6/2.8A	35 lbs. (16 kg)
7053501**	115V, 60 Hz, 4.4A	40 lbs. (18 kg)

CFM @ Static Pressure — Inches of H ₂ O						
S.P.	0.0"	0.125"	0.25"	0.50"	0.75"	0.87"
CFM	595	560	515	420	300	167

Contact Labconco for more information.

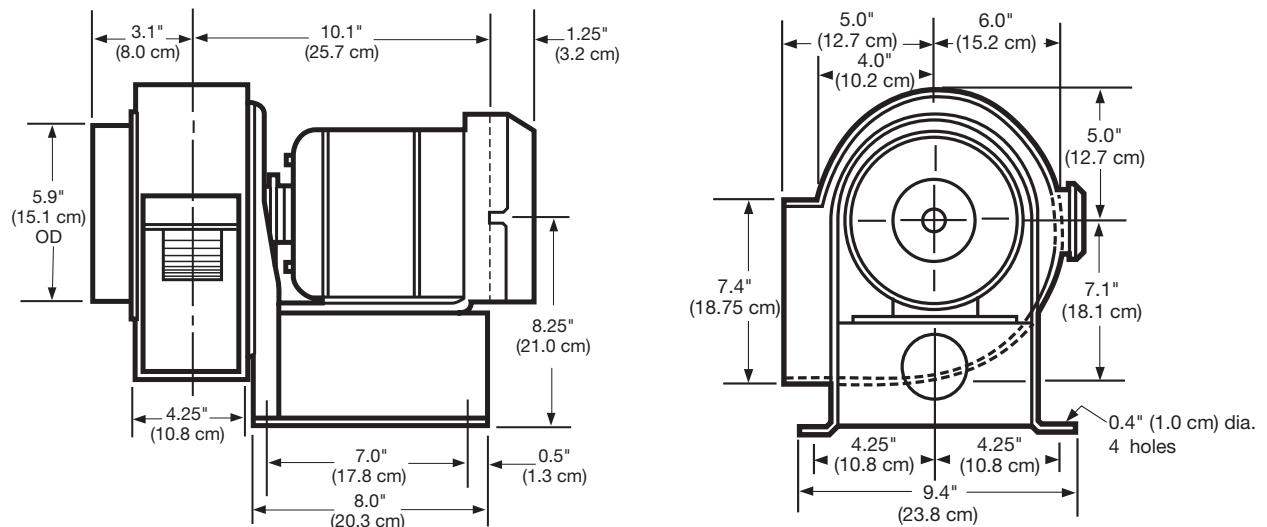

*International electrical configuration

**Explosion-proof

[†]Equivalent resistance is measured in feet of straight duct.

Accessories

Protector® XVS Ventilation Stations & Protector® Demonstration Hoods

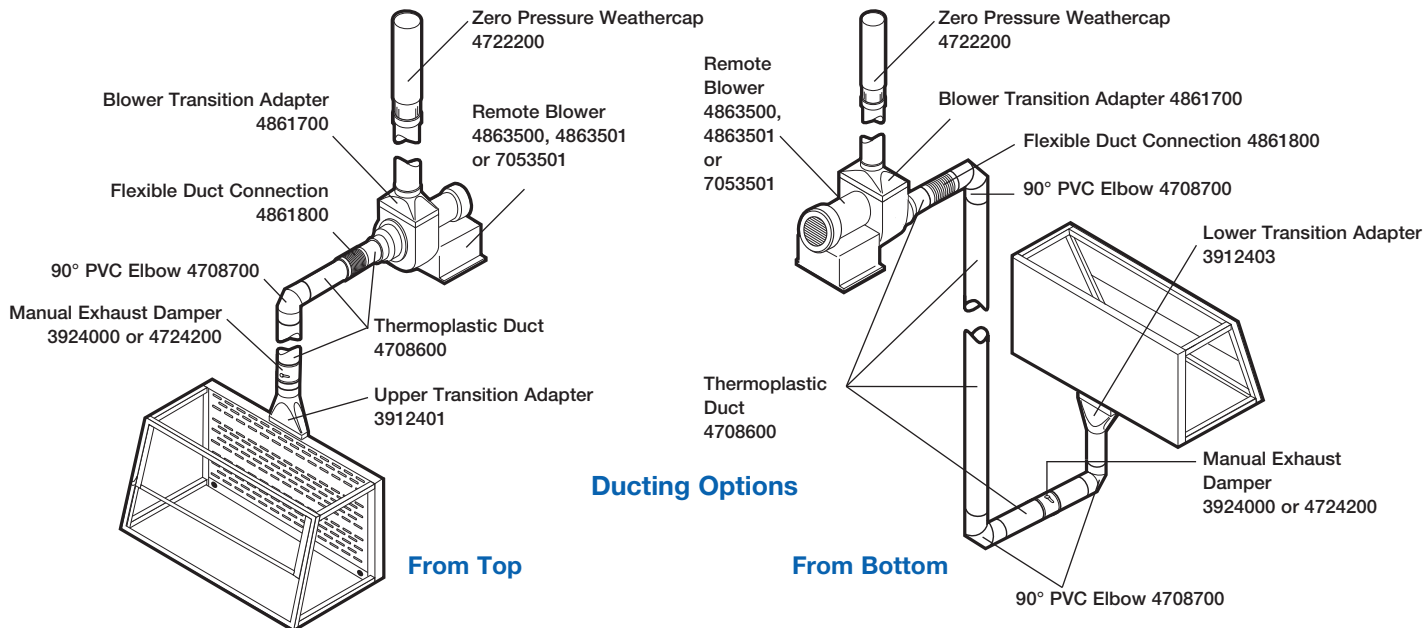

Guardian™ 1000 Digital Airflow Monitors. Mount atop Protector XVS Ventilation Stations and Protector Demonstration Hoods in factory-prepared location. Monitor and alert the operator to low airflow conditions. Include face plate with circuit board, electrical power pack, airflow hose, flow hose adapter and glacier white powder-coated steel casing. LCD displays actual airflow in fpm or m/sec from 0 to 999 fpm (0 to 5.0 m/s). Audible/visual alarm alerts user to sustained low velocity condition. Calibration instructions displayed on LCD. LED lights display red for alarm, yellow for caution, green for normal. Include temperature-compensated airflow sensor, external alarm, RS-232 port, night setback and alarm mute functions. UL* and CE listed.

Catalog Number	Electrical Requirements	Shipping Weight
3908800	115V, 60 Hz	10 lbs. (5 kg)
3908801**	230V, 50 Hz	10 lbs. (5 kg)



Guardian™ 500 Airflow Monitors. Mount atop Protector XVS Ventilation Stations and Protector Demonstration Hoods in factory-prepared location. Include face plate with circuit board, electrical power pack, tubing, airflow tube adapter and glacier white powder-coated steel casing. From the monitor's face plate, the user can easily select and calibrate a setpoint between 30 and 250 fpm using a velocity meter and a screwdriver. A green LED glows to indicate "safe" when airflow is greater than the low setpoint. Red LED flashes to indicate "low" when airflow is below the low setpoint. Amber LED flashes when the sash is raised above the maximum safe working opening. Audible alarm sounds (and can be muted) when under "low" and "sash high" conditions. Include night setback, external alarm and alarm mute functions.

Catalog Number	Electrical Requirements	Shipping Weight
3944700	115V, 60 Hz	10 lbs. (5 kg)
3944701**	230V, 50 Hz	10 lbs. (5 kg)

*UL is a registered trademark of UL, LLC.

**International electrical configuration



LABCONCO CORPORATION

8811 Prospect Avenue
Kansas City, MO 64132

(800) 821-5525 | (816) 333-8811

labconco.com



©2018 LABCONCO CORPORATION

Printed in the U.S.A.

Product design subject to change without notice.

2-88-06/01/26