

Mobile Self-Leveling Cabinets

Adjust-a-Fit® Adjustable Diameter - Heated

Models 917, 927, 937, 955
965, 975, 919, 929

Spec. #



Model 927

Adjustable Diameter And Dispensing Height Adjustments Without Tools

- Three tube sizes, each with a 3-1/4" diameter adjustment range
- Height adjustment springs detach and attach from inside the dispenser - no need to remove dispenser from mobile unit
- All-welded stainless steel construction
- Corner bumpers protect cabinet, furniture and doors
- Each heated dispenser features its own switch and thermostatic control
- Easy-Glide™ design provides quiet, non-stick operation
- 4" Lake-Glide® casters - all swivel, 2 each with brake

AIA #

Specifications



Mobile Cabinet: Mobile cabinets are of all-welded stainless steel construction, with 18 gauge top and 20-gauge sides and bottom and include bottom corner bumpers. Cabinet bottom has center clean out hole. Casters are 4" (102 mm) diameter extra-load swivel (two with locking brake). Unit features a heavy-duty independent undercarriage frame of galvanized steel to which casters are mounted. Units are NSF listed.

Dispenser Tubes: Dispenser tubes are of welded stainless steel construction and drop in to mobile cabinet top openings. Dispensers hang from cabinet opening by an 18-gauge flange ring and feature three each 22-gauge vertical side supports welded to 20-gauge bottom plate. Self-leveling dish carriage is of welded stainless steel construction and travels vertically in dispenser tube with three sets of nylon roller guides running in vertical tracks for smooth operation. Carriage has 22-gauge removable dish platform. Dispensers feature flange-mounted perimeter extension springs, which are detachable from the dish carriage to provide proper dish height adjustment without tools. Dispensers also feature three stainless steel dish guides running the entire height of the dispenser. Dish guides pivot to provide diameter adjustability of 3/4" (83 mm) without tools or removing components to accommodate various diameter dishes. Each dispenser has a vertical stacking capacity of 25" (635 mm).

Heating System: Unit is 120 VAC 60 Hz and has a 6' (1829 mm) coiled power supply cord with 5-15P NEMA plug for 120 VAC. Cabinet has interior mounted electrical junction box with twist-lock receptacles for individual power to each dispenser. Dispenser tubes are fully enclosed in 22-gauge stainless steel, and have a circular bottom mounted 300 or 450 watt heater element to provide convection heat. Heating system features thermostatic control in a tamper protective location with safe high-end shut-off. Control has infinite settings between low and high temperature cut-outs. Thermostat is field adjustable for average interior air temperature between 100°F (38°C) and 175° F (79°C) at middle adjustable thermostatic setting. On-off switch and power indicator light are mounted on top flange of each dispenser. Average dish temperature rise of 40°F (22°C) above ambient is achieved within one hour of initial heating cycle at middle adjustable thermostatic setting. Cabinet and dispenser tubes are U.L. listed.

Lakeside Manufacturing, Inc.

4900 West Electric Avenue • West Milwaukee, WI 53219 U.S.A.

800-558-8565 • 414-902-6400 • Fax 414-902-6446 • info@eLakeside.com • www.eLakeside.com/foodservice

Mobile Self-Leveling Cabinets

Adjust-a-Fit® Adjustable Diameter - Heated

Models

917, 927

937, 955

965, 975

919, 929

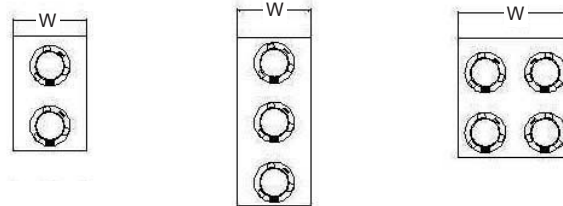
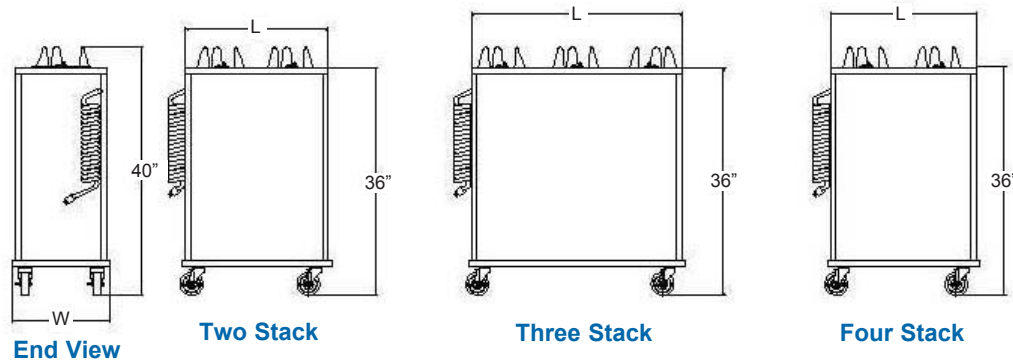

Plan Views

AutoCAD drawings available through KCL CADalog

Model Information

Model	Adjusts To Fit Plate Size		Overall Size						Electrical		Ship Wt.	
			W	L	H	W	L	H	Watts	Amps	lbs.	(kg.)
2-Stack Models												
917	4-1/4" to 7-1/2"	(108 to 191)	17-1/4"	26-1/8"	39-1/8"	(438	664	994)	600	5.0	113	(51.3)
927	6-1/2" to 9-3/4"	(165 to 248)	17-1/4"	30-5/8"	39-1/8"	(438	778	994)	900	7.5	126	(57.2)
937	8-3/4 to 12"	(222 to 305)	19-1/2"	35-1/8"	39-1/8"	(495	892	994)	900	7.5	142	(64.4)
3-Stack Models												
955	4-1/4" to 7-1/2"	(108 to 191)	17-1/4"	38-5/16"	39-1/8"	(438	973	994)	900	7.5	151	(68.5)
965	6-1/2" to 9-3/4"	(165 to 248)	17-1/4"	45"	39-1/8"	(438	1145	994)	1350	11.3	167	(75.8)
975	8-3/4 to 12"	(222 to 305)	19-3/16"	51-13/16"	39-1/8"	(487	1316	994)	1200	10.0	175	(79.4)
4-Stack Models												
919	4-1/4" to 7-1/2"	(108 to 191)	30-5/8"	30-5/8"	39-1/8"	(778	778	994)	1350	11.3	190	(86.2)
929	6-1/2" to 9-3/4"	(165 to 248)	30-5/8"	30-5/8"	39-1/8"	(778	778	994)	1350	11.3	196	(88.9)

Measurements in () denote metric millimeters, unless otherwise specified.

OPTIONAL ACCESSORIES

- Stainless steel dispenser tube covers
- Laminate or vinyl decorative exterior finishes
- 8" 1-piece vertical handle (except 4-stack)
- 208/240 VAC 60Hz
- 220 VAC 50 Hz
- Full-perimeter bumper



Lakeside Manufacturing, Inc.
 4900 West Electric Avenue • West Milwaukee, WI 53219 U.S.A.
 800-558-8565 • 414-902-6400 • Fax 414-902-6446
 Info@elakeside.com • www.elakeside.com/foodservice