

## Stainless Steel Utility Carts

### Medium Duty - 500 Lb. Capacity

Models 411, 422, 444, 444ES, 459

### Ideal For All-Purpose Back-Of-The-House Tasks

- Durable, unitized electronically welded angle leg frame
- 20-gauge stainless steel reinforced shelves
- Protective bumpers on legs and handle protect furnishings
- Sound deadening panels under shelves reduce vibrations and noise
- 500 lb. (230 kg.) load capacity
- Model 444ES is based on Model 444 with a reduced overall height of 32-1/2", making the 444ES Easy-Ship™ eligible via UPS Ground and FedEx Ground



Model 422



Model 444ES

### Specifications:

Unit shall be of fully welded unitized construction with an overall carrying capacity of 500 pounds. Corner legs shall be of 16-gauge angle stainless steel. Shelves shall be of 20-gauge stainless steel with long shelf edges double hemmed for extra strength, and shall be electronically spot welded to upright legs at all points. Unit shall have a stainless steel push handle welded to frame, and shall have corner bumpers mounted to front legs and ends of push handle. Unit shall have an independent galvanized steel dolly frame fastened to the bottom with 8 screws. Four each 4" swivel casters shall be mounted to the dolly frame.

#### Models 444, 444ES and 459 Only

Unit shall have 4 each 5" diameter swivel casters with non-marking polyurethane wheels. Welded assembly shall have triangular stainless steel reinforcing gussets welded to four bottom corners. Top shelf shall have 16-gauge angle reinforcements welded to long shelf edges.

Spec. #

AIA #

Lakeside Manufacturing, Inc.

4900 West Electric Avenue • West Milwaukee, WI 53219 U.S.A.

800-558-8565 • 414-902-6400 • Fax 414-902-6446 • info@eLakeside.com • www.eLakeside.com/foodservice

**Models**  
**411, 422**  
**444, 444ES**  
**459**

# Stainless Steel Utility Carts

Medium Duty - 500 Lb. Capacity

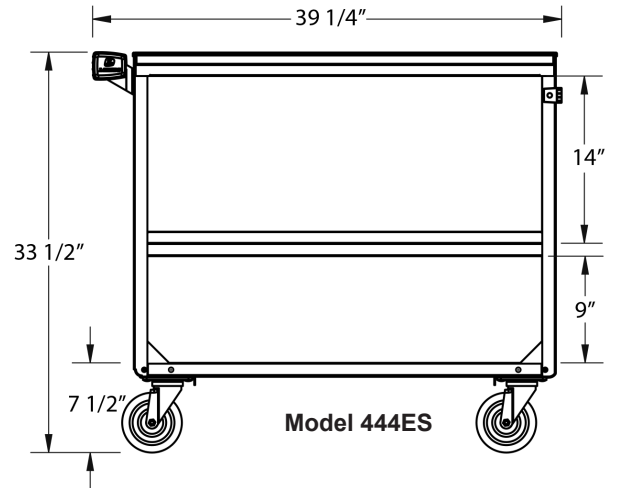
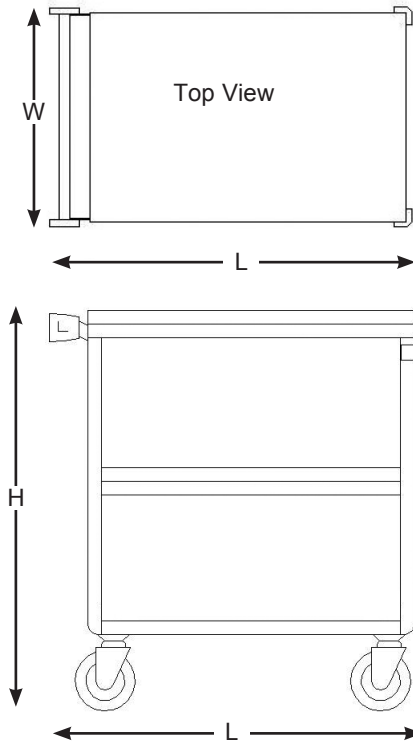

### Optional Accessories

(411, 422, 444 and 459)

- Perimeter shelf mounted strip bumper
- Cushion tread wheels
- Clear vinyl slipover box type cover

(models 444, and 459)

- Extended perimeter bumper
- 8" swivel casters

(all models)

- Set of two each brake casters

## Model Information

Model	UPS	Shelves		Overall Size			Casters		Case Weight	
		Size	Clearance (C)	W	L	H	Type	Dia.	Lbs.	(kg)
411	Yes	15-1/2" x 24" (394 x 610)	11-1/2" (302)	16-3/4" (425)	27-5/8" (702)	32" (813)	All swivel	4" (102)	39	(17.7)
422	Yes	18" x 27" (457 x 686)	11-1/2" (302)	19" (483)	31" (787)	32" (813)	All swivel	4" (102)	42	(19.1)
444	No	21" x 35" (533 x 889)	13-1/8" (333)	22-3/8" (568)	39-1/4" (997)	37-1/4" (946)	All swivel	5" (127)	68	(30.8)
444ES	Yes	21" x 35" (533 x 889)	14" (355) 9" (227)	22-3/8" (568)	39-1/4" (997)	33 1/2" (851)	All swivel	5" (127)	67	(30.3)
459	No	21" x 49" (533 x 1245)	13-1/8" (333)	22-3/8" (568)	54-1/8" (1374)	37-1/4" (946)	2 swivel 2 fixed	5" (127)	88	(39.9)

Measurements in ( ) denote metric millimeters, unless otherwise specified.



Lakeside Manufacturing, Inc.  
 4900 West Electric Avenue • West Milwaukee, WI 53219 U.S.A.  
 800-558-8565 • 414-902-6400 • Fax 414-902-6446  
 info@eLakeside.com • www.eLakeside.com/foodservice