

# XLERATOR® HAND DRYER



MODELS: **XL - BW W GR C SB SI SP** OPTIONS: **-H** (HEPA Filter) **-1.1N** (Noise Reduction Nozzle) **-VOLTAGE** (See Chart)



**XL-SB**

Brushed Stainless Steel

**XL-BW-H**

White Thermoset Resin (BMC)

## PERFORMANCE



**DRY TIME: 8 SECONDS<sup>1</sup>**

**ENERGY PER USE: 1.7 Wh<sup>1</sup>**

## DATA BASED ON ALL XL .8 NOZZLE DRYERS INCLUDING eHEPA® MODELS

**SOUND:** 62 - 75 dB(a) Average

**VELOCITY:** 12,000 - 20,000 LFM @ Air Outlet

**FLOW RATE:** 39 - 64 CFM

**MOTOR RPM:** Up to 24,000 RPM

**HEAT RANGE:** OFF to HIGH: 90°F - 145°F Average @ Air Outlet

**WATTAGE:** ~1,450 Watts (Heat On) ~510 Watts (Heat Off)

## CONSTRUCTION

A. All covers will be fastened to a base plate by two chrome plated tamper-proof bolts. Cover shall be one of the following:

**Die-cast zinc alloy** – One-piece, heavy-duty, rib-reinforced, lightweight, unbreakable, rustproof and all exposed surfaces shall be bright chrome plated or finished with chip-proof, electrostatically applied epoxy paint.

**Bulk Molding Compound (BMC)** – White reinforced thermoset resin.

**Stainless Steel** – with a brushed finish.

**Special Image** – Digital image applied to die-cast or stainless steel covers using patented Kolorfusion Sublimation Decoration process.

B. Base plate shall be equipped with (3) 7/8" (22 mm) diameter holes, the bottom one is suitable for use with surface conduit.

C. All internal parts shall be coated according to Underwriters' Laboratories, Inc. requirements.

D. Entire mechanism shall be internally grounded.

E. Options:

**Electrostatic HEPA (eHEPA®) Filtration System:** Removes 99.999% of viruses and 99.97% of potentially present bacteria<sup>2</sup> at 0.3 microns from the airstream.

**1.1" Noise Reduction Nozzle:** Reduces the sound level by 9 decibels by significantly decreasing air deflection noise while only increasing dry time by approximately 3 seconds.

F. Gel coating available on metal covers to reduce exposure to contaminants that can cause staining or corrosion, added cost may apply.

G. Accessories (optional):

**Antimicrobial Wall Guards:** 89W (Microban® White), 89B (Microban Black), 89S (Brushed Stainless Steel)

**XChanger Paper Towel Dispenser Retrofit Kit:** 40575, 40576 (ADA Height)

**ADA-Compliant Recess Kit:** 40505/40502

## MECHANISM

A. **New 50% longer life motor** shall be a thermally protected, series commutated, through-flow discharge vacuum motor/blower (5/8 hp / 24,000 rpm) which provides air velocity of up to 20,000 LFM (linear feet per minute). Includes a washable metal mesh filter for more reliable performance.

B. Heating element (970 W) is constructed of Nichrome wire and mounted inside the blower housing, thereby being vandal resistant. It shall be protected by an automatic resetting thermostat, which shall open whenever air flow is cut off and shall close when flow of air is resumed. It shall produce an average air temperature at the outlet of up to 145°F (63°C) at a 72°F (22°C) ambient room temperature.

C. Control assembly is activated by an infrared optical sensor located next to the air outlet. The dryer shall operate as long as hands are under the air outlet. Control includes a speed and sound control mechanism, adjustable heat control with High, Medium, Low and Off settings and a filter sensor which is activated should the filter become clogged. There is a 35-second lockout feature if hands are not removed. Sensor equipped with externally visible red LED that flashes error codes to assist in troubleshooting.



**XL-SP-H<sup>3</sup>**

Custom Special Paint



**XL-GR-H**

Graphite Textured Painted



**XL-W-H**

White Epoxy Painted



**XL-SI<sup>4</sup>**

Custom Special Image



**XL-C**

Chrome Plated



**XL-SB**

Brushed Stainless Steel



UL Environment published the first global Product Category Rules (PCR) for Hand Dryers. The PCR created evaluation methods through industry consensus that compare products' environmental impact and performance. Third-party testing results then allow for the creation of certified Environmental Product Declarations (EPDs).



Smart EPD® verifies Environmental Product Declarations (EPDs) for consistency with the LCA and conformance with global Product Category Rules (PCR) for hand dryers. UL Environment published the first global PCR for hand dryers. Third-party testing to these guidelines documents a product's environmental impact over its lifecycle. This impact is detailed in Environmental Product Declarations, enabling specifiers and buyers to make true apples-to-apples comparisons and more informed product selections. Excel Dryer received the industry's first certified EPDs.

<sup>1</sup>Dry time and energy use testing performed by SGS International on standard XLERATOR Hand Dryer with 0.8" nozzle to 0.25g of residual moisture, pursuant to the UL Environment Global Product Category Rules (PCR) for Hand Dryers. <sup>2</sup>Based on testing performed by LMS Technologies, 2023. <sup>3</sup>Special Paint powder-coated covers are available in many colors and textures. <sup>4</sup>Exclusive digital image technology allows for the addition of company, school or team logos with any color, design or a 'green message'.

## LIMITED WARRANTY

The dryer shall be guaranteed to be free from defects for a period of **seven (7) years**. Warranty shall include labor performed at factory as well as the repair or exchange of defective parts, at manufacturer's option.

## QUANTITY RECOMMENDATIONS

One dryer for every two washbasins is sufficient for most applications. If restroom traffic is unusually heavy, we suggest one dryer per washbasin in small installations and two dryers for every three washbasins in larger installations. When a 54" washfountain is used, we suggest four to five dryers.

# XLERATOR® HAND DRYER



MODELS: **XL - BW W GR C SB SI SP** OPTIONS: **-H** (HEPA Filter) **-1.1N** (Noise Reduction Nozzle) **-VOLTAGE** (See Chart)

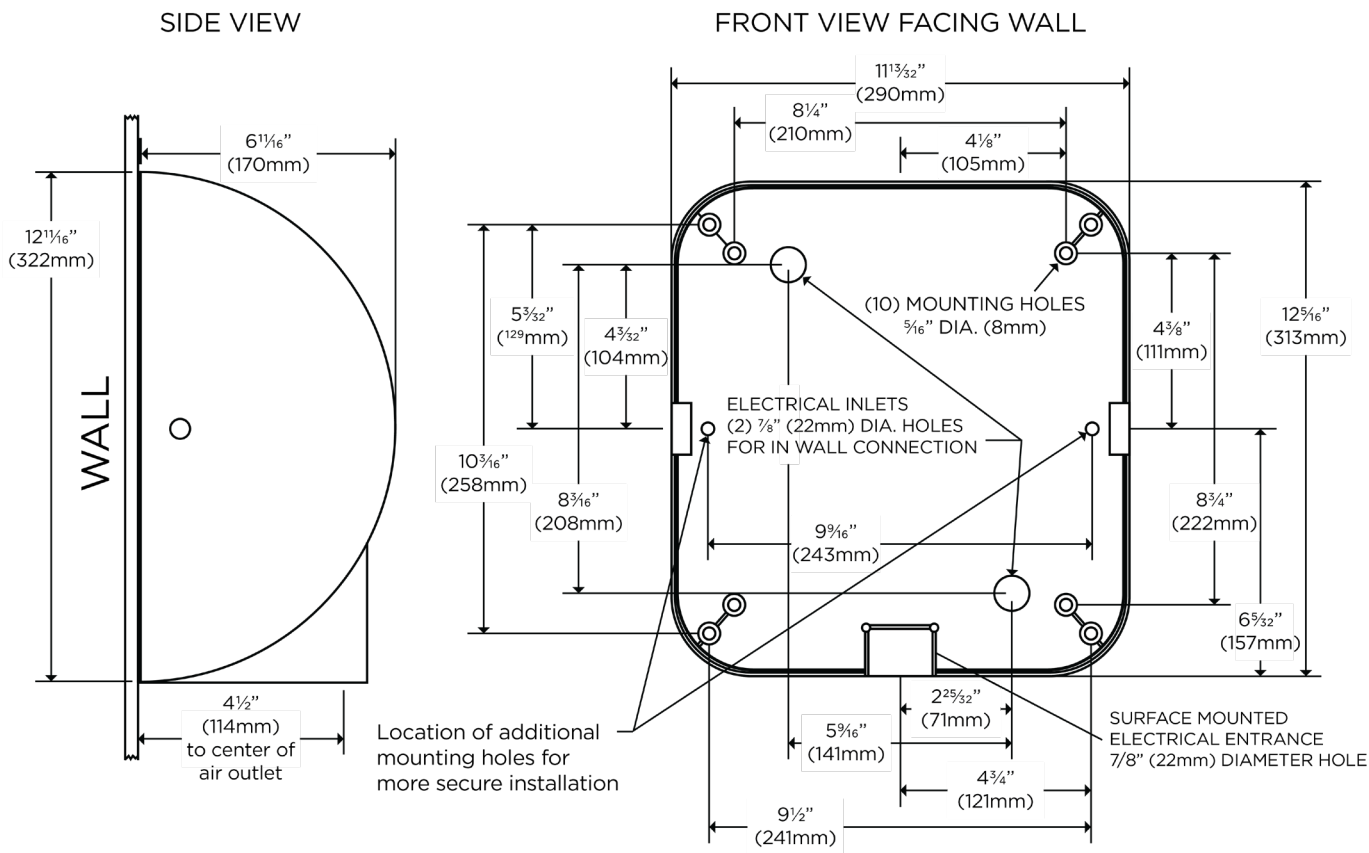

## DIMENSIONS

Width 11 3/4" (298 mm) Height 12 11/16" (322 mm) Depth 6 11/16" (170 mm)

## WEIGHT

XL-BW: 12.4 lbs. (5.62 kgs.) XL-SB: 16 lbs. (7.26 kgs.) XL-W, GR, C, SI, SP: 17 lbs. (7.71 kgs.)

## ELECTRICAL

VOLTS	AMPS	WATTS	AMPS (HEAT OFF)	WATTS (HEAT OFF)	HERTZ	LISTING
110-120V	11.3-12.2A	1,213-1,450W	4.3-4.5A	442-513W	50/60 Hz	cULus
208-240V	5.6-6.2A	1,135-1,450W	2.0-2.2A	495W	50/60 Hz	cULus
208-277V	5.6-6.2A	1,135-1,450W	2.0-2.2A	416-495W	50/60 Hz	UL
230V	6.1A	1,400W	2.1A	500W	50-60 Hz	CE

## SUGGESTED MOUNTING HEIGHTS from floor to bottom of dryer:

Men	45" (114 cm)
Women	43" (109 cm)
Teenagers	41" (104 cm)
Small Children	35" (89 cm)
Accessible	37" (94 cm)

## CERTIFICATIONS



## ACTIVATION

Automatic Sensor Operated

## MOUNTING

Surface-Mounted

## OPTIONAL ADA-COMPLIANT RECESS KIT



Part # 40505/40502

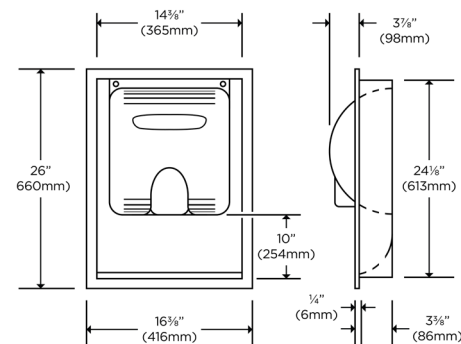

## DIMENSIONS

Width 16 3/8" (416 mm) Height 26" (660 mm) Depth 3 3/8" (86 mm)

Bottom of recessed wall box should be 10" (254 mm) below suggested mounting height for dryer.

<sup>1</sup>Dry time and energy use testing performed by SGS International on standard XLERATOR Hand Dryer with 0.8" nozzle to 0.25g or less of residual moisture, pursuant to the UL Environment Global Product Category Rules (PCR) for Hand Dryers. <sup>2</sup>Based on testing performed by LMS Technologies, 2023. <sup>3</sup>Special Paint powder-coated covers are available in many colors and textures. <sup>4</sup>Exclusive digital image technology allows for the addition of company, school or team logos with any color, design or a 'green message'.